

300

150

0

COBRA
DARK
SPEED

cobra®

2024 PRODUCT CATALOG



TABLE OF CONTENTS

04	DRIVERS
12	JUNIORS
14	FAIRWAYS / HYBRIDS
22	IRONS
35	WEDGES
52	PUTTERS
70	ARCCOS CADDIE
71	COMPLETE SETS
76	ACCESSORIES



DARK SPEED

DRIVER TECHNOLOGY

Designed by Aerospace Engineers, the Darkspeed Drivers feature dramatic improvements in aero shaping and internal and external technologies to deliver out of this world speed.

LARGER PWRSHELL H.O.T. FACE

A 10% larger PWRSHELL L-cup face maximizes launch and distance, while an A.I. designed H.O.T. Face delivers more efficient speed & spin across the clubface.

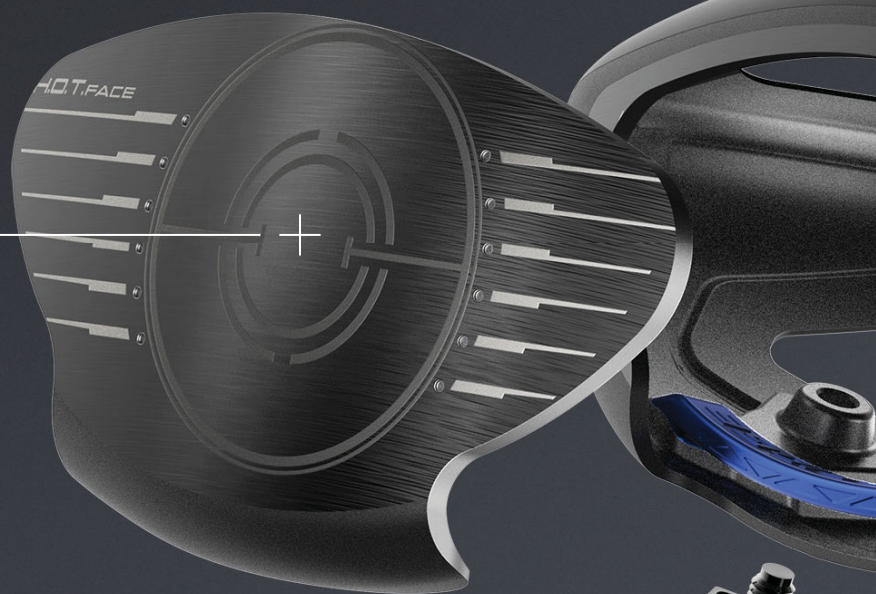

LOWER & MORE FORWARD PWR-BRIDGE

A lower and more forward positioning of the suspended PWR-BRIDGE weight unleashes even faster ball speeds.





CARBON CROWN AND SOLE

A lightweight carbon crown and sole piece replaces Titanium, allowing for better redistribution of weight to improve mass properties.

FASTER AERO SHAPING

An improved aero shape features a streamlined topline radius, a higher crown peak, raised skirt and reduced clubface surface area to maximize speed.

ENHANCED TRAJECTORY TUNING

The LS, X, and MAX models feature more adjustability options for a better ability to optimize spin & forgiveness.

DARK DRIVERS SPEED

The DARKSPEED drivers feature an improved aero shape, a larger PWRSHELL Face, and a lower and more forward PWR-BRIDGE to deliver more ball speed and distance. Three models (LS, X, and MAX) utilize specific weighting configurations to tailor performance for each player target.

The LS model features a Tour inspired shape for better players that demand low spin and low launch for maximum workability and control.



REFINED AERODYNAMIC DESIGN

An improved aero shape features a streamlined face to topline radius, a higher crown peak, raised skirt and reduced clubface surface area to maximize speed.

TOUR INSPIRED SHAPING

A refined clubhead shape features a reduced visual footprint at address that promotes workability and control.

LARGER PWRSHELL WITH A.I. DESIGNED H.O.T. FACE

A 10% larger PWRSHELL L-cup face creates more robust distance, while an A.I. designed H.O.T. Face delivers more efficient speed & spin across the clubface.

UNLOCK FASTER BALL SPEED

A lower and more forward positioning of the suspended PWR-BRIDGE weight unleashes even faster ball speeds.

MAX WORKABILITY WITH ADDED FORGIVENESS

Adjustable heel and toe weights are now complemented with a third back weight, allowing for additional adjustment to optimize spin & forgiveness.



Free Arccos sensors with purchase

LOFT	LOFT & LIE SETTINGS									WEIGHT ADJUSTABILITY	LENGTH	SHAFT OFFERING / FLEX / SWING WEIGHT	RH/LH
	-1.5°	-1°	-1°D	STD°	STD°D	+1°	+1°D	+1.5°					
8.0°	6.5° (55.50°)	7.0° (55.80°)	7.0°D (56.10°)	8.0° (54.20°)	8.0°D (56.80°)	9.0° (54.80°)	9.0°D (56.10°)	9.5° (55.50°)		HEEL/TOE/BACK	45.50"	UST LIN-Q M40X White 6 (F5 - X, F4 - S): D3 HZRDUS Black Gen 4 60 (S): D4	RH
9.0°	7.5° (57.00°)	8.0° (56.30°)	8.0°D (57.60°)	9.0° (55.70°)	9.0°D (58.30°)	10.0° (56.30°)	10.0°D (57.60°)	10.5° (57.00°)		HEEL/TOE/BACK	45.50"	UST LIN-Q M40X White 6 (F5 - X, F4 - S): D3 HZRDUS Black Gen 4 60 (S): D4	RH/LH
10.5°	9.0° (57.00°)	9.5° (56.30°)	9.5°D (57.60°)	10.5° (55.70°)	10.5°D (58.30°)	11.5° (56.30°)	11.5°D (57.60°)	12.0° (57.00°)		HEEL/TOE/BACK	45.50"	UST LIN-Q M40X White 6 (F4 - S): D3 HZRDUS Black Gen 4 60 (S): D4 UST LIN-Q M40X Blue 6 (F4 - S, F3 - R): D2.5	RH/*LH

*LH custom only

GRIP	SHAFT	COLORS
<ul style="list-style-type: none"> GRIP0195 Lamkin Crossline Black STD 58R (48g) 	<ul style="list-style-type: none"> UST LIN-Q M40X Blue 6 (67g) (F4 - S, F3 - R) UST LIN-Q M40X White 6 (67g) (F5 - X, F4 - S) Project X HZRDUS Black Gen 4 Matte Finish (60g) (6.0 - S) 	<ul style="list-style-type: none"> Crown Color: Satin Black Carbon

The X model is designed for Tour and amateurs seeking a fast, low spin head that offers medium launch and plenty of forgiveness.



REFINED AERODYNAMIC DESIGN

An improved aero shape features a streamlined face to topline radius, a higher crown peak, raised skirt and reduced clubface surface area to maximize speed.

TOUR INSPIRED SHAPING

A refined clubhead shape features an elevated look at address that promotes workability and control with added forgiveness.

LARGER PWRSHELL WITH A.I. DESIGNED H.O.T. FACE

A 10% larger PWRSHELL L-cup face creates more robust distance, while an A.I. designed H.O.T. Face delivers more efficient speed & spin across the clubface.

UNLOCK FASTER BALL SPEED

A lower and more forward positioning of the suspended PWR-BRIDGE weight unleashes even faster ball speeds.

BLEND OF FORGIVENESS & SPIN CONTROL

A back weight is now accompanied by a second forward weight, allowing for additional spin tuning control.



Free Arccos sensors with purchase

LOFT	LOFT & LIE SETTINGS	WEIGHT ADJUSTABILITY	LENGTH	SHAFT OFFERING / FLEX / SWING WEIGHT	RH/LH
	-1.5° -1° -1°D STD° STD°D +1° +1°D +1.5°				
9.0°	7.5° 8.0° 8.0°D 9.0° 9.0°D 10.0° 10.0°D 10.5° (57.50°) (56.80°) (58.10°) (56.20°) (58.80°) (56.80°) (58.10°) (57.50°)	MID/BACK	45.50"	UST LIN-Q M40X White 6 (F5 - X, F4 - S): D2.5 UST LIN-Q M40X Blue 6 (S - D2.5, R - D2) HZRDUS Black Gen 4 60 (S): D3.5	RH/*LH
10.5°	9.0° 9.5° 9.5°D 10.5° 10.5°D 11.5° 11.5°D 12.0° (58.50°) (57.80°) (59.10°) (57.20°) (59.80°) (57.80°) (59.10°) (58.50°)	MID/BACK	45.50"	UST LIN-Q M40X White 6 (F4 - S): D2.5 UST LIN-Q M40X Blue 6 (S - D2.5, R - D2) UST LIN-Q M40X Red 6 (F2 - A): D1.5 MCA Kai'li Blue 60 (S, R): D4	RH/LH
12.0°	10.5° 11.0° 11.0°D 12.0° 12.0°D 13.0° 13.0°D 13.5° (58.50°) (57.80°) (59.10°) (57.20°) (59.80°) (57.80°) (59.10°) (58.50°)	MID/BACK	45.50"	MCA Kai'li Blue 60 (R): D4 Project HZRDUS Red CB (A): D1	RH

GRIP	SHAFT	COLORS
<ul style="list-style-type: none"> GRIP0195 Lamkin Crossline Black STD 58R (48g) 	<ul style="list-style-type: none"> Project X HZRDUS Red CB 50 (52g) (5.0 - A) UST LIN-Q M40X Red 5 (58g) (F2 - A) UST LIN-Q M40X Blue 6 (67g) (F4 - S, F3 - R) MCA Kai'li Blue 60 (66.5g) (S, R) UST LIN-Q M40X White 6 (67g) (F5 - X, F4 - S) 	<ul style="list-style-type: none"> Crown Color: Satin Black Carbon Accent Colors: Blue

The MAX model delivers draw-bias and unrivaled stability in a low-mid spin design for ultimate distance and accuracy.



REFINED AERODYNAMIC DESIGN

An improved aero shape features a streamlined face to topline radius, a higher crown peak, raised skirt and reduced clubface surface area to maximize speed.

SHAPED FOR SPEED AND FORGIVENESS

A refined clubhead shape blends speed with forgiveness for an elevated look at address that inspires maximum confidence on the tee.

MORE ROBUST LAUNCH

A 10% larger PWR-SHELL L-cup face maximizes launch and distance, while an A.I. designed H.O.T. Face delivers more efficient speed & spin across the clubface.

UNLOCK FASTER BALL SPEED

A lower and more forward positioning of the suspended PWR-BRIDGE weight unleashes even faster ball speeds.

MAX FORGIVENESS & DRAW-BIASED CONTROL

Adjustable back and heel weight positions allow you to fine-tune draw bias in our most forgiving driver head.



Free Arccos sensors with purchase

LOFT	LOFT & LIE SETTINGS									WEIGHT ADJUSTABILITY	LENGTH	SHAFT OFFERING / FLEX / SWING WEIGHT	RH/LH
	-1.5°	-1°	-1°D	STD°	STD°D	+1°	+1°D	+1.5°					
9.0°	7.5° (59.50°)	8.0° (58.80°)	8.0°D (60.10°)	9.0° (59.20°)	9.0°D (60.80°)	10.0° (58.80°)	10.0°D (60.10°)	10.5° (59.50°)		BACK/HEEL	45.50"	UST LIN-Q M40X Red 6 (F4 - S, F3 - R): D1.5	RH
10.5°	9.0° (60.50°)	9.5° (59.80°)	9.5°D (61.10°)	10.5° (59.20°)	10.5°D (61.80°)	11.5° (59.80°)	11.5°D (61.10°)	12.0° (60.50°)		BACK/HEEL	45.50"	UST LIN-Q M40X Red 6 (F4 - S, F3 - R): D1.5 Project HZRDUUS Red CB (R, A): D1	RH/LH
12.0°	10.5° (60.50°)	11.0° (59.80°)	11.0°D (61.10°)	12.0° (59.20°)	12.0°D (61.80°)	13.0° (59.80°)	13.0°D (61.10°)	13.5° (60.50°)		BACK/HEEL	45.50"	Project HZRDUUS Red CB (R, A): D1	RH/*LH

*LH custom only

GRIP	SHAFT	COLORS
<ul style="list-style-type: none"> GRIP0195 Lamkin Crossline Black STD 58R (48g) 	<ul style="list-style-type: none"> Project X HZRDUUS Red CB 50 (52g) (R, A) UST LIN-Q M40X Red 50 (F4 - S, F3 - R) (57g) 	<ul style="list-style-type: none"> Crown Color: Satin Black Carbon Accent Colors: Red

The MAX Women's model delivers draw-bias and unrivaled stability in a mid spin design for ultimate distance and accuracy.



REFINED AERODYNAMIC DESIGN

An improved aero shape features a streamlined face to topline radius, a higher crown peak, raised skirt and reduced clubface surface area to maximize speed.

SHAPED FOR SPEED AND FORGIVENESS

A refined clubhead shape blends speed with forgiveness for an elevated look at address that inspires maximum confidence on the tee.

MORE ROBUST LAUNCH

A 10% larger PWR-SHELL L-cup face maximizes launch and distance, while an A.I. designed H.O.T. Face delivers more efficient speed & spin across the clubface.

UNLOCK FASTER BALL SPEED

A lower and more forward positioning of the suspended PWR-BRIDGE weight unleashes even faster ball speeds.

MAX FORGIVENESS & DRAW-BIASED CONTROL

Adjustable back and heel weight positions allow you to fine-tune draw bias in our most forgiving driver head.



Free Arccos sensors with purchase

LOFT	LOFT & LIE SETTINGS									WEIGHT ADJUSTABILITY	LENGTH	SHAFT OFFERING / FLEX / SWING WEIGHT	RH/LH
	-1.5°	-1°	-1°D	STD°	STD°D	+1°	+1°D	+1.5°					
10.5°	9.0° (60.50°)	9.5° (59.80°)	9.5°D (61.10°)	10.5° (59.20°)	10.5°D (61.80°)	11.5° (59.80°)	11.5°D (61.10°)	12.0° (60.50°)	BACK/HEEL	44.00"	UST Helium Nanocore 4F1 (L): C5	RH/*LH	
12.0°	10.5° (60.50°)	11.0° (59.80°)	11.0°D (61.10°)	12.0° (59.20°)	12.0°D (61.80°)	13.0° (59.80°)	13.0°D (61.10°)	13.5° (60.50°)	BACK/HEEL	44.00"	UST Helium Nanocore 4F1 (L): C5	RH/*LH	

**LH custom only*

GRIP	SHAFT	COLORS
<ul style="list-style-type: none"> GRIP0197 Lamkin Crossline Black Undersize 60R (45g) 	<ul style="list-style-type: none"> UST Helium Nanocore 4F1 (43g) 	<ul style="list-style-type: none"> Crown Color: Gloss Black Carbon Accent Colors: Cool Blue / Silver

The MAX Junior model delivers draw-bias and unrivaled stability in a low-mid spin design for ultimate distance and accuracy. Juniors receive a free shaft upgrade with their purchase as they grow into their game.



REFINED AERODYNAMIC DESIGN

An improved aero shape features a streamlined face to topline radius, a higher crown peak, raised skirt and reduced clubface surface area to maximize speed.

SHAPED FOR SPEED AND FORGIVENESS

A refined clubhead shape blends speed with forgiveness for an elevated look at address that inspires maximum confidence on the tee.

MORE ROBUST LAUNCH

A 10% larger PWRSHELL L-cup face maximizes launch and distance, while an A.I. designed H.O.T. Face delivers more efficient speed & spin across the clubface.



UNLOCK FASTER BALL SPEED

A lower and more forward positioning of the suspended PWR-BRIDGE weight unleashes even faster ball speeds.

MAX FORGIVENESS & DRAW-BIASED CONTROL

Adjustable back and heel weight positions allow you to fine-tune draw bias in our most forgiving driver head.

LOFT	LOFT & LIE SETTINGS									WEIGHT ADJUSTABILITY	LENGTH	SHAFT OFFERING / FLEX / SWING WEIGHT	RH/LH
	-1.5°	-1°	-1°D	STD°	STD°D	+1°	+1°D	+1.5°					
12.0°	10.5° (60.50°)	11.0° (59.80°)	11.0°D (61.10°)	12.0° (59.20°)	12.0°D (61.80°)	13.0° (59.80°)	13.0°D (61.10°)	13.5° (60.50°)	BACK/HEEL	39.00" (8-9 yrs) 41.00" (10-11 yrs) 43.00" (12-14 yrs)	Cobra Junior (Junior flex - 46g): A3 Cobra Junior (Junior flex - 60.5g): B3 Cobra Junior (Junior flex - 60.5g) :C3	RH	

GRIP	SHAFT	COLORS
<ul style="list-style-type: none"> GRIP0197 Lamkin Crossline Black Undersize 60R (45g) 	<ul style="list-style-type: none"> Cobra Junior Graphite (high launch / high spin) 	<ul style="list-style-type: none"> Crown Color: Satin Black Carbon Accent Colors: Red

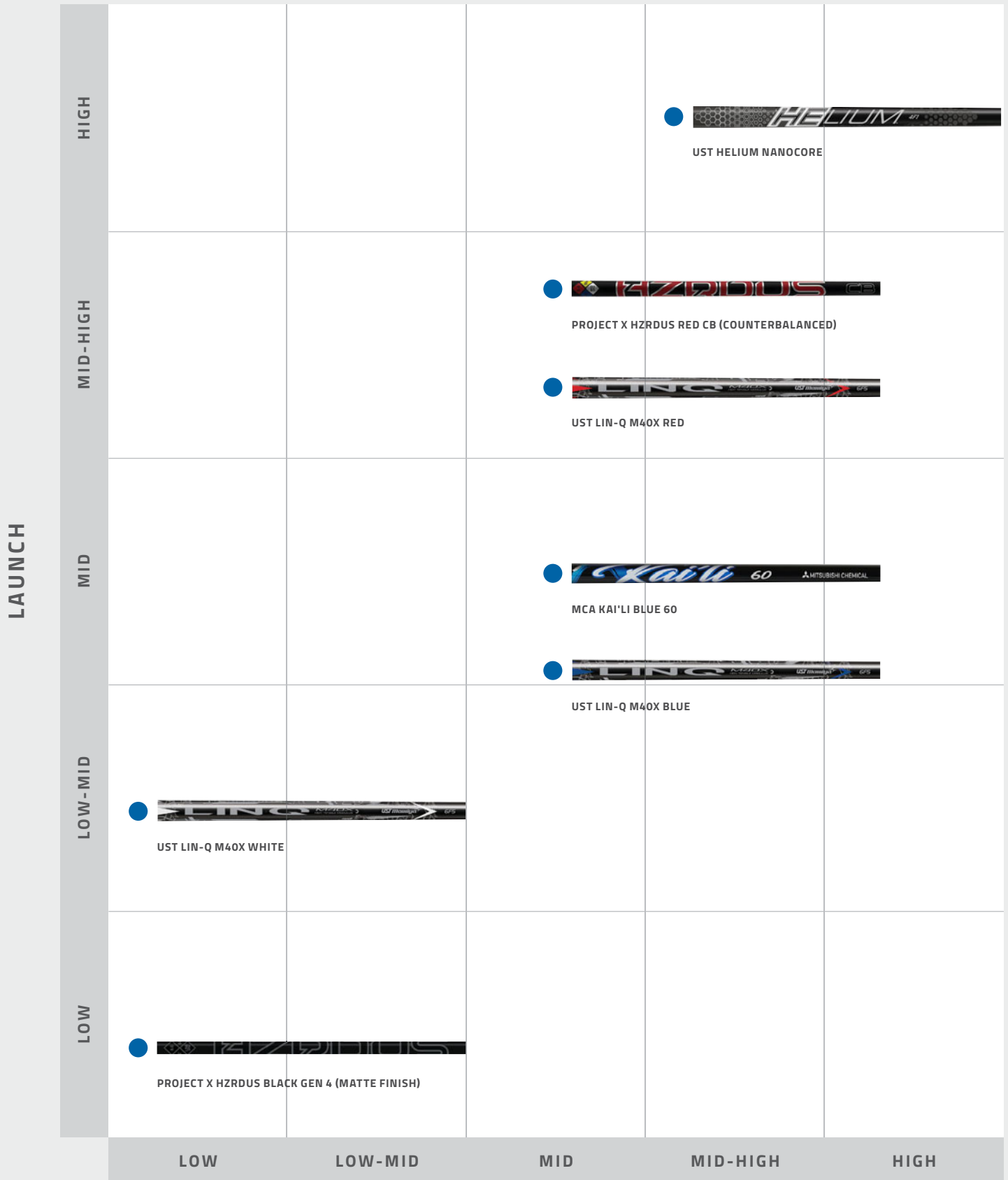

SPIN

DARK SPEED

FAIRWAY TECHNOLOGY

The LS model is our first fairway featuring a Titanium construction, delivering driver-like performance, and significant distance gains compared to a traditional fairway design.

CARBON CROWN

A lightweight carbon crown replaces Titanium, allowing for better redistribution of weight to improve mass properties.

LARGER PWRSHELL H.O.T. FACE

An A.I. designed PWRSHELL H.O.T. Face features an optimized variable thickness pattern that delivers more efficient speed & spin across the clubface.

TUNGSTEN WEIGHTING

Internal tungsten weights are strategically positioned in the heel and toe areas to improve stability for tighter dispersion and pinpoint accuracy.

ENHANCED TRAJECTORY TUNING

In the LS model, adjustable heel and toe weights are now complemented with a third back weight, allowing for additional adjustment to optimize spin & forgiveness.

LOWER & MORE FORWARD PWR-BRIDGE

A lower and more forward positioning of the suspended PWR-BRIDGE weight unleashes even faster ball speeds.



The LS model features our first ever Titanium fairway construction for driver-like performance in a refined clubhead shape tailored for precise shot shaping.



TOUR INSPIRED SHAPING

Subdued clubhead styling inspires a Tour-validated look and feel at address.

TITANIUM CONSTRUCTION

A multi-material construction blends a lightweight 8-1-1 Titanium body and face, and a carbon crown to improve weight distribution for more distance.

TIGHTER DISPERSION WITH TUNGSTEN WEIGHTING

Internal and external tungsten weights are strategically positioned in the heel and toe areas to improve stability for tighter dispersion and pinpoint accuracy.

FASTER BALL SPEED

The PWR-SHELL insert and suspended PWR-BRIDGE design create a more flexible face and sole for penetrating launch and maximum ball speed.

SPEED & SPIN OPTIMIZATION

An A.I. designed H.O.T. Face features an optimized variable thickness pattern that delivers more efficient speed & spin across the clubface.

MAX WORKABILITY WITH ADDED FORGIVENESS

Adjustable heel and toe weights are now complemented with a third back weight, allowing for additional adjustment to optimize spin & forgiveness.



Free Arccos sensors with purchase

CLUB	LOFT & LIE SETTINGS									WEIGHT ADJUSTABILITY	LENGTH	SHAFT OFFERING / FLEX / SWING WEIGHT	RH/LH
	-1.5°	-1°	-1°D	STD°	STD°D	+1°	+1°D	+1.5°					
3+	11.5° (57.00°)	12.0° (56.30°)	12.0°D (57.60°)	13.0° (57.70°)	13.0°D (58.30°)	14.0° (56.30°)	14.0°D (57.60°)	14.5° (57.00°)		HEEL/TOE/BACK	43.00"	UST LIN-Q M40X White 7 (F5 - X, F4 - S): D1.5	RH
3	13.0° (57.00°)	13.5° (56.30°)	13.5°D (57.60°)	14.5° (57.70°)	14.5°D (58.30°)	15.5° (56.30°)	15.5°D (57.60°)	16.0° (57.00°)		HEEL/TOE/BACK	43.00"	UST LIN-Q M40X White 7 (F5 - X, F4 - S): D1.5	RH/*LH
5	16.0° (57.50°)	16.5° (56.80°)	16.50°D (58.10°)	17.5° (56.20°)	17.5°D (58.80°)	18.0° (56.80°)	18.5°D (58.10°)	19.0° (57.50°)		HEEL/TOE/BACK	42.50"	UST LIN-Q M40X White 7 (F4 - S): D2.5	RH/*LH

*LH custom only

GRIP	SHAFT	COLORS
<ul style="list-style-type: none"> GRIP0195 Lamkin Crossline Black STD 58R (48g) 	<ul style="list-style-type: none"> UST LIN-Q M40X White 7 (75g) (F5 - X, F4 - S) 	<ul style="list-style-type: none"> Crown Color: Satin Black Carbon

The X model is designed for versatile shot making and plenty of forgiveness to make your long game more consistent.



MORE LAUNCH. MORE BALL SPEED.

The PWR-SHELL insert and suspended weight PWR-BRIDGE design create a more flexible face and sole to maximize launch and ball speed.

SPEED & SPIN OPTIMIZATION

An A.I. designed H.O.T. Face features an optimized variable thickness pattern that delivers more efficient speed & spin across the clubface.

FORGIVENESS & HIGH LAUNCH

A back weight is utilized to promote high, towering ball flights for maximum carry distance.

TIGHTER DISPERSION

A lightweight carbon crown improves weight distribution to position the CG lower and further back, creating a more playable clubhead.



Free Arccos sensors with purchase

CLUB	LOFT & LIE SETTINGS									WEIGHT ADJUSTABILITY	LENGTH	SHAFT OFFERING / FLEX / SWING WEIGHT	RH/LH
	-1.5°	-1°	-1°D	STD°	STD°D	+1°	+1°D	+1.5°					
3	13.5° (58.00°)	14.0° (57.30°)	14.0°D (58.60°)	15.0° (56.70°)	15.0°D (59.30°)	16.0° (57.30°)	16.0°D (58.60°)	16.5° (58.00°)		FIXED BACK	43.00"	UST LIN-Q M40X Blue 6 (F5 - X, F4 - S, F3 - R): D0.5 UST LIN-Q M40X Red 5 (F2 - A): C9	RH/*LH
3 HF	15.0° (58.00°)	15.5° (57.30°)	15.5°D (58.60°)	16.5° (56.70°)	16.5°D (59.30°)	16.0° (57.30°)	16.0°D (58.60°)	16.5° (58.00°)		FIXED BACK	43.00"	UST LIN-Q M40X Blue 6 (F4 - S, F3 - R): D0.5 UST LIN-Q M40X Red 5 (F2 - A): C9	RH
5	16.5° (58.75°)	17.0° (58.00°)	17.0°D (59.40°)	18.0° (57.50°)	18.0°D (60.10°)	19.0° (58.00°)	19.0°D (59.40°)	19.5° (58.75°)		FIXED BACK	42.50"	UST LIN-Q M40X Blue 6 (F4 - S, F3 - R): D0.5 UST LIN-Q M40X Red 5 (F2 - A): C9	RH/*LH
7	19.5° (59.50°)	20.0° (58.80°)	20.0°D (60.10°)	21.0° (58.20°)	21.0°D (60.80°)	22.0° (58.80°)	22.0°D (60.10°)	22.5° (59.50°)		FIXED BACK	42.00"	UST LIN-Q M40X Blue 6 (F4 - S, F3 - R): D0.5	RH/*LH

GRIP	SHAFT	COLORS
<ul style="list-style-type: none"> GRIP0195 Lamkin Crossline Black STD 58R (48g) 	<ul style="list-style-type: none"> UST LIN-Q M40X Red 5 (58g) (F2 - A) UST LIN-Q M40X Blue 6 (67g) (F5 - X, F4 - S, F3 - R) 	<ul style="list-style-type: none"> Crown Color: Satin Black Carbon Accent Colors: Blue

The MAX model features tunable draw-bias and unrivaled stability to inspire maximum confidence from the fairway or off the tee.



MORE LAUNCH. MORE BALL SPEED.

The PWR-SHELL insert and suspended weight PWR-BRIDGE design create a more flexible face and sole to maximize launch and ball speed.

SPEED & SPIN OPTIMIZATION

An A.I. designed H.O.T. Face features an optimized variable thickness pattern that delivers more efficient speed & spin across the clubface.

MAX FORGIVENESS & DRAW-BIASED CONTROL

Adjustable back and heel weight positions allow you to fine-tune draw bias in our most forgiving head.

TIGHTER DISPERSION

A lightweight carbon crown improves weight distribution to position the CG lower and further back, creating a more playable clubhead.



Free Arccos sensors with purchase

CLUB	LOFT & LIE SETTINGS									WEIGHT ADJUSTABILITY	LENGTH	SHAFT OFFERING / FLEX / SWING WEIGHT	RH/LH
	-1.5°	-1°	-1°D	STD°	STD°D	+1°	+1°D	+1.5°					
3	14.0° (59.00°)	14.5° (58.30°)	14.5°D (59.60°)	15.5° (57.70°)	15.5°D (60.30°)	16.5° (58.30°)	16.5°D (59.60°)	17.0° (59.00°)		BACK/HEEL	43.00"	UST LIN-Q M40X Red 5 (F4 - S, F3 - R, F2 - A): C9.5	RH/*LH
5	17.0° (59.75°)	17.5° (59.00°)	17.5°D (60.40°)	18.5° (58.50°)	18.5°D (61.10°)	19.5° (59.00°)	19.5°D (60.40°)	20.0° (59.75°)		BACK/HEEL	42.50"	UST LIN-Q M40X Red 5 (F4 - S, F3 - R, F2 - A): C9.5	RH/*LH
7	20.0° (60.50°)	20.5° (59.80°)	20.5°D (61.10°)	21.5° (59.20°)	21.5°D (61.80°)	22.5° (59.80°)	22.5°D (61.10°)	23.0° (60.50°)		BACK/HEEL	42.00"	UST LIN-Q M40X Red 5 (F3 - R, F2 - A): C9.5	RH/*LH

GRIP	SHAFT	COLORS
<ul style="list-style-type: none"> GRIP0195 Lamkin Crossline Black STD 58R (48g) 	<ul style="list-style-type: none"> UST LIN-Q M40X Red 5 (58g) (F4 - S, F3 - R, F2 - A) 	<ul style="list-style-type: none"> Crown Color: Satin Black Carbon Accent Colors: Red

The MAX Women's model features tunable draw-bias and unrivaled stability to inspire maximum confidence from the fairway or off the tee.



MORE LAUNCH. MORE BALL SPEED.

The PWR-SHELL insert and suspended weight PWR-BRIDGE design create a more flexible face and sole to maximize launch and ball speed.

SPEED & SPIN OPTIMIZATION

An A.I. designed H.O.T. Face features an optimized variable thickness pattern that delivers more efficient speed & spin across the clubface.

MAX FORGIVENESS & DRAW-BIASED CONTROL

Adjustable back and heel weight positions allow you to fine-tune draw bias in our most forgiving head.

TIGHTER DISPERSION

A lightweight carbon crown improves weight distribution to position the CG lower and further back, creating a more playable clubhead.



Free Arccos sensors with purchase

CLUB	LOFT & LIE SETTINGS									WEIGHT ADJUSTABILITY	LENGTH	SHAFT OFFERING / FLEX / SWING WEIGHT	RH/LH
	-1.5°	-1°	-1°D	STD°	STD°D	+1°	+1°D	+1.5°					
3	17.0° (59.75°)	17.5° (59.00°)	17.5°D (60.40°)	18.5° (58.50°)	18.5°D (61.10°)	19.5° (59.00°)	19.5°D (60.40°)	20.0° (59.75°)		BACK/HEEL	41.75"	UST Helium Nanocore 4F1 (L): C4	RH/*LH
5	20.0° (60.50°)	20.5° (59.80°)	20.5°D (61.10°)	21.5° (59.20°)	21.5°D (61.80°)	22.5° (59.80°)	22.5°D (61.10°)	23.0° (60.50°)		BACK/HEEL	41.25"	UST Helium Nanocore 4F1 (L): C4	RH/*LH
7	23.0° (61.25°)	23.5° (60.55°)	23.5°D (61.90°)	24.5° (59.90°)	24.5°D (62.60°)	25.5° (60.55°)	25.5°D (61.90°)	26.0° (61.25°)		BACK/HEEL	40.75"	UST Helium Nanocore 4F1 (L): C4	RH

*LH custom only

GRIP	SHAFT	COLORS
<ul style="list-style-type: none"> GRIP0197 Lamkin Crossline Black Undersize 60R (45g) 	<ul style="list-style-type: none"> UST Helium Nanocore 4F1 (43g) 	<ul style="list-style-type: none"> Crown Color: Gloss Black Carbon Accent Colors: Cool Blue / Silver

The DARKSPEED hybrid blends distance and high launch to provide more forgiveness on longer approach shots and adaptability across different lies.



CONFIDENCE INSPIRING SHAPE

A deep body design paired with a high bounce leading edge provides improved turf interaction and stability through any turf condition.

FASTER BALL SPEED

The PWR-SHELL insert and suspended PWR-BRIDGE design create a more flexible face and sole for penetrating launch and maximum ball speed.

SPEED & SPIN OPTIMIZATION

An A.I. designed H.O.T. Face features an optimized variable thickness pattern that delivers more efficient speed & spin across the clubface.

FORGIVENESS & HIGH LAUNCH

A 12g sole weight is positioned as low as possible to promote high, towering ball flights for maximum carry distance.



Free Arccos sensors with purchase



CLUB	LOFT	LIE ANGLE	LENGTH	SHAFT OFFERING / FLEX / SWING WEIGHT	RH/LH
2H	17.0°	57.50°	41.50"	KBS PGI 85 (S): D1	RH
3H	19.0°	58.00°	40.75"	KBS PGI 85 (S): D1, PGI 75 (R): D0	RH/*LH
4H	21.0°	58.50°	40.00"	KBS PGI 85 (S): D1, PGI 75 (R): D0, PGI 65 (A): C9	RH/*LH
5H	24.0°	59.00°	39.25"	KBS PGI 85 (S): D1, PGI 75 (R): D0, PGI 65 (A): C9	RH/*LH
*6H	28.0°	59.50°	38.50"	*Custom Only	*RH

3H: LH stock available in stiff flex only

4H: LH stock available in reg flex only

*LH custom only (5H)

*RH custom only (6H)

GRIP	SHAFT	COLORS
<ul style="list-style-type: none"> GRIP0195 Lamkin Crossline Black STD 58R (48g) 	<ul style="list-style-type: none"> KBS PGI 85 (80g), KBS PGI 75 (70g), KBS PGI 65 (60g) 	<ul style="list-style-type: none"> Crown Color: Satin Black

A ONE Length configuration allows you to utilize one repeatable setup and swing for increased confidence and consistency from every distance.



CONSISTENCY OF ONE LENGTH

Utilize one repeatable setup and swing for increased confidence and consistency from every distance.

CONFIDENCE INSPIRING SHAPE

A deep body design paired with a high bounce leading edge provides improved turf interaction and stability through any turf condition.

FASTER BALL SPEED

The PWR-SHELL insert and suspended PWR-BRIDGE design create a more flexible face and sole for penetrating launch and maximum ball speed.

SPEED & SPIN OPTIMIZATION

An A.I. designed H.O.T. Face features an optimized variable thickness pattern that delivers more efficient speed & spin across the clubface.

FORGIVENESS & HIGH LAUNCH



A 12g sole weight is positioned as low as possible to promote high, towering ball flights for maximum carry distance.



Free Arccos sensors with purchase

CLUB	LOFT	LIE ANGLE	LENGTH	SHAFT OFFERING / FLEX / SWING WEIGHT	RH/LH
3H	19.0°	63.00°	37.25"	KBS PGI 85 (S: C9.5), 75 (R: C9)	RH
4H	21.0°	62.50°	37.25"	KBS PGI 85 (S: C9.5), 75 (R: C9)	RH
*5H	24.0°	62.00°	37.25"	*Custom Only	*RH

*Custom only

GRIP	SHAFT	COLORS
<ul style="list-style-type: none"> GRIP0196 Lamkin Crossline Black STD 58R (48g) 	<ul style="list-style-type: none"> KBS PGI 85 (80g), KBS PGI 75 (70g) 	<ul style="list-style-type: none"> Crown Color: Satin Black Accent Colors: Blue/Red

The DARKSPEED Women's hybrid blends distance and high launch to provide more forgiveness on longer approach shots and adaptability across different lies.



CONFIDENCE INSPIRING SHAPE

A deep body design paired with a high bounce leading edge provides improved turf interaction and stability through any turf condition.

FASTER BALL SPEED

The PWRSHELL insert and suspended PWR-BRIDGE design create a more flexible face and sole for penetrating launch and maximum ball speed.

SPEED & SPIN OPTIMIZATION

An A.I. designed H.O.T. Face features an optimized variable thickness pattern that delivers more efficient speed & spin across the clubface.

FORGIVENESS & HIGH LAUNCH

A 12g sole weight is positioned as low as possible to promote high, towering ball flights for maximum carry distance.



Free Arccos sensors with purchase

CLUB	LOFT	LIE ANGLE	LENGTH	SHAFT OFFERING / FLEX / SWING WEIGHT	RH/LH
4H	21.0°	58.50°	39.00"	KBS PGI 55 (Ladies flex): C3.5	RH/*LH
5H	24.0°	59.00°	38.25"	KBS PGI 55 (Ladies flex): C3.5	RH/*LH
6H	28.0°	59.50°	37.50"	KBS PGI 55 (Ladies flex): C3.5	RH/*LH
7H	31.0°	60.00°	36.75"	KBS PGI 55 (Ladies flex): C3.5	RH

*LH custom only

GRIP	SHAFT	COLORS
<ul style="list-style-type: none"> GRIP0197 Lamkin Crossline Black Undersize 60R (45g) 	<ul style="list-style-type: none"> KBS PGI 55 (50g) 	<ul style="list-style-type: none"> Crown Color: Gloss Black Accent Colors: Cool Blue / Silver

DARK SPEED

IRON TECHNOLOGY

Unlock your distance potential with an all new hollow construction that creates our longest and most robust iron design yet.

LARGER PWR SHELL H.O.T. FACE

A larger PWR SHELL L-cup face maximizes launch and distance, while an A.I. designed H.O.T. Face delivers more efficient speed & spin across the clubface.

SOFTER FOAM MICROSPHERES

The hollow cavity is filled with a softer 920D foam material that damps vibrations for improved sound and feel.

HOLLOW BODY CONSTRUCTION

A hollow metalwood construction creates a more unsupported face to maximize ball speed and distance.

PWR-BRIDGE WEIGHTING

A PWR-BRIDGE weight is suspended on a single post to encourage more body and face flexion for faster ball speed.



Unlock your distance potential with an all new hollow construction that creates our longest and most robust iron design yet.



POWERFUL BALL SPEED AND DISTANCE

A larger PWRSHELL insert and a refined PWR-BRIDGE weight create a more unsupported face for extreme flexibility and speed.

TUNED ACOUSTICS AND FEEL

The hollow cavity is filled with soft foam microspheres to deliver exceptional sound and feel.

EXTREME ACCURACY

An A.I. designed H.O.T. Face delivers more efficient speed and spin and produces a larger sweet spot for more looks at birdie.



Free Arccos sensors with purchase

CLUB	LOFT	LIE ANGLE	OFFSET (MM)	LENGTH	GRAPHITE SWING WEIGHT	STEEL SWING WEIGHT	GRAPHITE SHAFT FLEX	STEEL SHAFT FLEX	RH/LH
4	18.5°	62.00°	5.4	39.25"	D0.5 (S, R), C9.5 (A)	D1	S, R, A	S, R	RH/LH
5	21.0°	62.50°	4.6	38.50"	D0.5 (S, R), C9.5 (A)	D1	S, R, A	S, R	RH/LH
6	24.0°	63.00°	3.9	37.75"	D0.5 (S, R), C9.5 (A)	D1	S, R, A	S, R	RH/LH
7	27.0°	63.50°	3.2	37.25"	D0.5 (S, R), C9.5 (A)	D1	S, R, A	S, R	RH/LH
8	31.5°	64.00°	2.6	36.75"	D0.5 (S, R), C9.5 (A)	D1	S, R, A	S, R	RH/LH
9	36.5°	64.50°	2.0	36.25"	D0.5 (S, R), C9.5 (A)	D1	S, R, A	S, R	RH/LH
PW	42.0°	65.00°	1.5	36.00"	D1.5 (S, R), D0.5 (A)	D1.5	S, R, A	S, R	RH/LH
GW	47.5°	65.00°	1.0	35.75"	D1.5 (S, R), D0.5 (A)	D2	S, R, A	S, R	RH/LH
SW	54.0°	65.00°	1.0	35.50"	D1.5 (S, R), D0.5 (A)	D2	S, R, A	S, R	RH/LH

STOCK SET COMPOSITION	GRIP	SHAFT	COLORS
<p>Graphite Combo: 5H, 6-GW (R, A; RH/*LH custom)</p> <p>Steel Irons: 5-GW (SR - RH/LH, SS - RH only), 4-PW (SS - RH only)</p>	<ul style="list-style-type: none"> GRIP0195 Lamkin Crossline Black STD 58R (48g) 	<ul style="list-style-type: none"> Graphite: KBS PGI 85 (80g) - Stiff, KBS PGI 75 (70g) - Reg, KBS PGI 65 (60g) - Lite Steel: KBS Tour Lite (105g - S, R) <p>*Graphite is stock in combo sets only; Graphite iron sets available through custom only</p>	<ul style="list-style-type: none"> Dark Satin Grey

Our longest iron meets unmatched consistency and accuracy in a ONE Length configuration.



CONSISTENCY OF ONE LENGTH

Utilize one repeatable setup and swing for increased confidence and consistency from every distance.

POWERFUL BALL SPEED AND DISTANCE

A larger PWR-SHELL insert and a refined PWR-BRIDGE weight create a more unsupported face for extreme flexibility and speed.

TUNED ACOUSTICS AND FEEL

The hollow cavity is filled with soft foam microspheres to deliver exceptional sound and feel.

EXTREME ACCURACY

An A.I. designed H.O.T. Face delivers more efficient speed and spin and produces a larger sweet spot for more looks at birdie.



Free Arccos sensors with purchase

CLUB	LOFT	LIE ANGLE	OFFSET (MM)	LENGTH	GRAPHITE SWING WEIGHT	STEEL SWING WEIGHT	GRAPHITE SHAFT FLEX	STEEL SHAFT FLEX	RH/LH
4	19.0°	65.00°	6.0	37.25"	D1 (S), D0.5 (R), C9.5 (A)	D1	S, R, A	S, R	RH/LH
5	22.0°	64.50°	5.1	37.25"	D1 (S), D0.5 (R), C9.5 (A)	D1	S, R, A	S, R	RH/LH
6	24.5°	64.00°	4.2	37.25"	D1 (S), D0.5 (R), C9.5 (A)	D1	S, R, A	S, R	RH/LH
7	27.0°	63.50°	3.2	37.25"	D1 (S), D0.5 (R), C9.5 (A)	D1	S, R, A	S, R	RH/LH
8	31.5°	63.00°	2.6	37.25"	D1 (S), D0.5 (R), C9.5 (A)	D1	S, R, A	S, R	RH/LH
9	36.5°	62.50°	2.0	37.25"	D1 (S), D0.5 (R), C9.5 (A)	D1	S, R, A	S, R	RH/LH
PW	42.0°	62.00°	1.5	37.25"	D1 (S), D0.5 (R), C9.5 (A)	D1	S, R, A	S, R	RH/LH
GW	47.5°	61.50°	1.0	37.25"	D1 (S), D0.5 (R), C9.5 (A)	D1	S, R, A	S, R	RH/LH
SW	54.0°	61.50°	0.5	37.25"	D1 (S), D0.5 (R), C9.5 (A)	D1	S, R, A	S, R	RH/LH

STOCK SET COMPOSITION	GRIP	SHAFT	COLORS
Graphite Irons: 5-GW (GR - RH only) Steel Irons: 5-GW (SR - RH only, SS - RH only)	<ul style="list-style-type: none"> GRIP0196 Lamkin Crossline Black STD 58R (48g) 	<ul style="list-style-type: none"> Graphite: KBS PGI 85 (80g) - Stiff, KBS PGI 75 (70g) - Reg, KBS PGI 65 (60g) - Lite Steel: KBS Tour Lite (105g - S, R) 	<ul style="list-style-type: none"> Dark Satin Grey With Blue and Red Accents

Unlock your distance potential with an all new hollow construction that creates our longest and most robust iron design yet.



POWERFUL BALL SPEED AND DISTANCE

A larger PWR-SHELL insert and a refined PWR-BRIDGE weight create a more unsupported face for extreme flexibility and speed.

TUNED ACOUSTICS AND FEEL

The hollow cavity is filled with soft foam microspheres to deliver exceptional sound and feel.

EXTREME ACCURACY

An A.I. designed H.O.T. Face delivers more efficient speed and spin and produces a larger sweet spot for more looks at birdie.





Free Arccos sensors with purchase

CLUB	LOFT	LIE ANGLE	LENGTH	SHAFT FLEX	SWING WEIGHT	RH/LH
5H	24.0°	59.00°	38.25"	L	C3.5	RH/*LH
6H	28.0°	59.50°	37.50"	L	C3.5	RH/*LH

CLUB	LOFT	LIE ANGLE	OFFSET (MM)	LENGTH	SHAFT FLEX	SWING WEIGHT	RH/LH
5	21.0°	62.50°	4.6	37.50"	L	C3.5	*RH/*LH
6	24.0°	63.00°	3.9	36.75"	L	C3.5	*RH/*LH
7	27.0°	63.50°	3.2	36.25"	L	C3.5	RH/*LH
8	31.5°	64.00°	2.6	35.75"	L	C3.5	RH/*LH
9	36.5°	64.50°	2	35.25"	L	C4	RH/*LH
PW	42.0°	65.00°	1.5	35.00"	L	C4	RH/*LH
GW	47.5°	65.00°	1	34.75"	L	C4	*RH/*LH
SW	54.0°	65.00°	1	34.50"	L	C4	RH/*LH

*LH custom only

STOCK SET COMPOSITION	GRIP	SHAFT	COLORS
<p>Graphite Combo: 5H, 6H, 7-PW, SW (RH only)</p> <p>*Graphite and steel iron sets available through custom only</p> <p>*5i, 6i, GW single sticks are custom only for both RH & LH</p>	<ul style="list-style-type: none"> GRIP0197 Lamkin Crossline Black Undersize 60R (45g) 	<ul style="list-style-type: none"> KBS PGI 55 (50g) - L 	<ul style="list-style-type: none"> Dark Satin Grey With Cool Blue Accents



KING[®]

IRONS

A 5-step forged construction, a compact tour cavity back shape, and a TPU insert deliver soft feel with excellent feedback that skilled players demand.



ELEGANT SHAPING

A compact address profile inspires precision and workability with a touch of forgiveness provided by the cavity back design.

5-STEP FORGED

Crafted and 5-step forged from 1025 carbon steel for exceptional feel and compact shaping

TPU INSERT FOR ENHANCED FEEL

A TPU insert behind the sweet spot creates a satisfying soft feel

ALUMINUM MEDALLION

An aluminum medallion enables better weight distribution for added forgiveness when you need it.



Free Arccos sensors with purchase

CLUB	LOFT	LIE ANGLE	OFFSET (MM)	LENGTH	STEEL SWING WEIGHT	STEEL SHAFT FLEX	RH/LH
3	19.0°	60.00°	3.8	39.25"	D2	S, R	*RH/*LH
4	22.0°	60.50°	3.4	38.75"	D2	S, R	RH/*LH
5	25.0°	61.00°	3.1	38.25"	D2	S, R	RH/*LH
6	28.0°	61.50°	2.9	37.75"	D2	S, R	RH/*LH
7	32.0°	62.00°	2.5	37.25"	D2	S, R	RH/*LH
8	36.0°	62.50°	2.3	36.75"	D2	S, R	RH/*LH
9	40.0°	63.00°	2.1	36.25"	D2	S, R	RH/*LH
PW	44.0°	63.50°	1.9	36.00"	D3	S, R	RH/*LH
GW	48.0°	63.50°	1.9	35.75"	D3	S, R	*RH/*LH

*LH custom only

STOCK SET COMPOSITION	GRIP	SHAFT	COLORS
Steel Irons: 4-PW, Steel Stiff, RH Only *3i and GW single sticks are custom only for RH & LH	<ul style="list-style-type: none"> GRIP0195 Lamkin Crossline Black STD 58R (48g) 	<ul style="list-style-type: none"> KBS \$-Taper (120g) 	<ul style="list-style-type: none"> Chrome

Crafted for the blade aficionados, the traditionalists, and those that aspire for nothing but the best ball striking experience possible.



5-STEP FORGED

Crafted and 5-step forged from 1025 carbon steel for exceptional feel and compact shaping.

TOUR INSPIRED SHAPING

Using Tour feedback, the design has been refined to deliver sleek muscle back and cavity back shapes that inspires precision and workability.

FLOW SET

Available in a combo set that flows from a more forgiving muscle cavity back in the 4-6 iron, to a more workable muscle back in the 7 through Sand Wedge.



Free Arccos sensors with purchase

CLUB	LOFT	LIE ANGLE	OFFSET (MM) MB/CB	LENGTH	STEEL SWING WEIGHT	STEEL SHAFT FLEX	RH/LH
3	21.0°	60.00°	2.3 / 2.5	39.25"	D2	S, R	RH/*LH
4	24.0°	60.50°	2.0 / 2.3	38.75"	D2	S, R	RH/*LH
5	27.0°	61.00°	1.8 / 2.0	38.25"	D2	S, R	RH/*LH
6	30.0°	61.50°	1.5 / 1.8	37.75"	D2	S, R	RH/*LH
7	34.0°	62.00°	1.3 / 1.5	37.25"	D2	S, R	RH/*LH
8	38.0°	62.50°	1.3 / 1.3	36.75"	D2	S, R	RH/*LH
9	42.0°	63.00°	1.3 / 1.3	36.25"	D2	S, R	RH/*LH
PW	46.0°	63.50°	1.3 / 1.3	36.00"	D3	S, R	RH/*LH
GW	50.0°	63.50°	1.3 / 1.3	35.75"	D3	S, R	RH/*LH

*LH custom only

STOCK SET COMPOSITION	GRIP	SHAFT	COLORS
Steel Irons: 4-PW Flow Set (4-6 CB, 7-PW MB), Steel Stiff, RH Only Full CB sets available in custom (RH/LH) Full MB sets available in custom RH only	<ul style="list-style-type: none"> GRIP0195 Lamkin Crossline Black STD 58R (48g) 	<ul style="list-style-type: none"> KBS \$-Taper (120g) 	<ul style="list-style-type: none"> Chrome

Each iron is crafted using 1025 carbon steel and forged five times to deliver a player-preferred soft feel and a compact shape. A second black colorway features a durable DBM finish, and is available through custom only.



Free Arccos sensors with purchase



REFINED SHAPING

Experience unrivaled ball-striking through a sleeker and refined shape featuring a thinner topline and reduced offset that inspires precision and playability.

ENHANCED FEEL THROUGH FORGING & FOAM TECH

Each iron is crafted from 1025 carbon steel and precision-forged 5 times to deliver soft, player-preferred feel. A hollow body design is filled with a lightweight foam that enhances feel and feedback.

FORGIVING HOLLOW BODY DESIGN

Dynamic distance is unleashed using a hollow body, thinner PWRShell Face, and 20g of tungsten for added stability.

CLUB	LOFT	LIE ANGLE	OFFSET (MM)	LENGTH	STEEL SWING WEIGHT	STEEL SHAFT FLEX	RH/LH
3	19.0°	60.50°	3.9	39.25"	D2	S, R	*RH/*LH
4	21.0°	61.00°	3.6	38.75"	D2	S, R	RH/*LH
5	23.0°	61.50°	3.3	38.25"	D2	S, R	RH/*LH
6	26.0°	62.00°	3.0	37.75"	D2	S, R	RH/*LH
7	29.5°	62.50°	2.7	37.25"	D2	S, R	RH/*LH
8	34.0°	63.00°	2.4	36.75"	D2	S, R	RH/*LH
9	39.0°	63.50°	2.1	36.25"	D2	S, R	RH/*LH
PW	44.0°	64.00°	1.8	36.00"	D3	S, R	RH/*LH
GW	49.0°	64.00°	1.5	35.75"	D3	S, R	*RH/*LH

*LH custom only

STOCK SET COMPOSITION	GRIP	SHAFT	COLORS
Steel Irons: 4-PW, Steel Stiff & Steel Reg. RH (*LH custom) *3i and GW single sticks are custom only for RH & LH	<ul style="list-style-type: none"> GRIP0195 Lamkin Crossline Black STD 58R (48g) 	<ul style="list-style-type: none"> Steel: KBS \$-Taper Lite (110g) <p>*Graphite sold as custom only</p>	<ul style="list-style-type: none"> Chrome Black DBM (Custom Only)

The Forged TEC ONE Length Irons deliver enhanced consistency and accuracy for better players.



ONE LENGTH CONFIGURATION

ONE Length delivers improved consistency and accuracy by encouraging one repeatable setup, ball position, and swing for every iron.

REFINED SHAPING

Experience unrivaled ball-striking through a sleeker and refined shape featuring a thinner topline and reduced offset that inspires precision and playability.

ENHANCED FEEL THROUGH FORGING & FOAM TECH

Each iron is crafted from 1025 carbon steel and precision-forged 5 times to deliver soft, player-preferred feel. A hollow body design is filled with a lightweight foam that enhances feel and feedback.

FORGIVING HOLLOW BODY DESIGN

Dynamic distance is unleashed using a hollow body, thinner PWRSHELL Face, and 20g of tungsten for added stability.



Free Arccos sensors with purchase

CLUB	LOFT	LIE ANGLE	OFFSET (MM) MB/CB	LENGTH	STEEL SWING WEIGHT	STEEL SHAFT FLEX	RH/LH
4	21.0°	64.00°	4.2	37.25"	D2	S, R	*RH/*LH
5	23.0°	63.50°	3.6	37.25"	D2	S, R	RH/*LH
6	26.0°	63.00°	3.1	37.25"	D2	S, R	RH/*LH
7	29.5°	62.50°	2.7	37.25"	D2	S, R	RH/*LH
8	34.0°	62.00°	2.4	37.25"	D2	S, R	RH/*LH
9	39.0°	61.50°	2.1	37.25"	D2	S, R	RH/*LH
PW	44.0°	61.00°	1.8	37.25"	D3	S, R	RH/*LH
GW	49.0°	61.00°	1.5	37.25"	D3	S, R	RH/*LH

*LH custom only

*4i single stick custom only for RH & LH

STOCK SET COMPOSITION	GRIP	SHAFT	COLORS
Steel Irons: 5-GW, Steel Stiff & Steel Reg	<ul style="list-style-type: none"> GRIP0195 Lamkin Crossline Black STD 58R (48g) 	<ul style="list-style-type: none"> Steel: KBS \$-Taper Lite (110g) <p>*Graphite sold as custom only</p>	<ul style="list-style-type: none"> Chrome

Exhilarating distance and forgiveness is achieved through 65g of tungsten, and a hollow body design, giving you the keys to become the player you've always wanted to be.



PLAYERS LOOKS WITH FORGIVENESS

The Forged TEC X irons occupy a unique category of their own, offering unrivaled forgiveness with players' looks. Sleek shaping meets soft, forged-like feel, and 65g of tungsten for extreme stability.

FOAM INSERT FOR ENHANCED FEEL

A hollow body is filled with lightweight foam to create a softer, forged-like feel on every swing.

FORGIVING HOLLOW BODY DESIGN

Distance and forgiveness come to life using a hollow body construction, a thin forged PWRSHELL face, and 65g of tungsten.



Free Arccos sensors with purchase

CLUB	LOFT	LIE ANGLE	OFFSET (MM)	LENGTH	GRAPHITE SHAFT FLEX	GRAPHITE SWING WEIGHT	STEEL SHAFT FLEX	STEEL SWING WEIGHT	RH/LH
4	19.0°	62.00°	4.2	38.75"	*S, R	D1 (S), D0 (R)	S, R	D0	*RH/*LH
5	21.0°	62.50°	3.8	38.25"	*S, R	D1 (S), D0 (R)	S, R	D0	RH/*LH
6	24.0°	63.00°	3.4	37.75"	*S, R	D1 (S), D0 (R)	S, R	D0	RH/*LH
7	27.0°	63.50°	3.0	37.25"	*S, R	D1 (S), D0 (R)	S, R	D0	RH/*LH
8	31.5°	64.00°	2.6	36.75"	*S, R	D1 (S), D0 (R)	S, R	D0	RH/*LH
9	36.5°	64.50°	2.2	36.25"	*S, R	D1 (S), D0 (R)	S, R	D0	RH/*LH
PW	42.0°	65.00°	1.8	36.00"	*S, R	D1.5 (S), D0.5 (R)	S, R	D1	RH/*LH
GW	48.0°	65.00°	1.5	35.75"	*S, R	D1.5 (S), D0.5 (R)	S, R	D1	RH/*LH

*LH Steel Reg available through stock / Graphite Stiff available through custom only

*4i single stick custom only in RH & LH

STOCK SET COMPOSITION	GRIP	SHAFT	COLORS
Steel Irons: 5-GW, Steel Stiff & Steel Reg (LH stock available in steel reg only) Graphite Irons: 5-GW, Regular, RH	<ul style="list-style-type: none"> GRIP0195 Lamkin Crossline Black STD 58R (48g) 	<ul style="list-style-type: none"> Graphite: KBS TGI 85 (Stiff - 80g), TGI 75 (Regular - 70g) Steel: KBS Tour Lite (105g - S, R) 	<ul style="list-style-type: none"> Chrome

A highly versatile utility iron designed for skilled players that desire ultimate precision with a touch of forgiveness.



HOLLOW CONSTRUCTION

A hollow body is filled with a softer and lighter foam for added distance and improved feel.

TUNGSTEN WEIGHTING

A 61g tungsten weight keeps CG low to reduce spin for longer total distance.

FORGED PWRSHELL FACE

A forged PWRSHELL Face offers more flexibility than a traditional face insert, creating elastic rebound for faster ball speed and higher launch.

H.O.T. FACE TECHNOLOGY

H.O.T. Face Technology uses artificial intelligence to design a variable thickness pattern that delivers more efficient speed and spin across the face.





Free Arccos sensors with purchase

CLUB	LOFT	LIE ANGLE	OFFSET (MM)	GRAPHITE LENGTH	GRAPHITE SHAFT FLEX	GRAPHITE SWING WEIGHT	GRAPHITE RH/LH	STEEL LENGTH	STEEL SHAFT FLEX	STEEL SWING WEIGHT	STEEL RH/LH
2U	17.0°	59.75°	3.2	40.00"	*S, *R	D1	*RH	39.75"	S, R	D1.5	*RH
3U	19.0°	60.25°	3.2	39.50"	*S, *R	D1	RH	39.25"	S, R	D1.5	RH/*LH
4U	22.0°	60.75°	3.3	39.00"	*S, *R	D1	RH	38.75"	S, R	D1.5	RH/*LH
5U	25.0°	61.25°	3.3	38.50"	*S, *R	D1	*RH	38.25"	S, R	D1.5	*RH/*LH

3U & 4U stock graphite Stiff & Reg

2U & 5U graphite custom only

LH custom only in 3H, 4H, 5H

GRIP	SHAFT	COLORS
<ul style="list-style-type: none"> GRIP0195 Lamkin Crossline Black STD 58R (48g) 	<ul style="list-style-type: none"> Graphite: MCA MMT Hybrid 80 (S, R) - 85g Steel: KBS S-Taper Lite (S, R) - 110g  	<ul style="list-style-type: none"> Chrome

The ONE Length model delivers enhanced accuracy and consistency to those that desire a workable, yet slightly more forgiving utility iron.



ONE LENGTH CONFIGURATION

ONE Length delivers improved consistency and accuracy by encouraging one repeatable setup, ball position, and swing for every iron.

HOLLOW CONSTRUCTION

A hollow body is filled with a softer and lighter foam for added distance and improved feel

TUNGSTEN WEIGHTING

An 83g tungsten weight keeps CG low to reduce spin for longer total distance

FORGED PWRSHELL FACE

A forged PWRSHELL Face offers more flexibility than a traditional face insert, creating elastic rebound for faster ball speed and higher launch

H.O.T. FACE TECHNOLOGY

H.O.T. Face Technology uses artificial intelligence to design a variable thickness pattern that delivers more efficient speed and spin across the face





Free Arccos sensors with purchase

CLUB	LOFT	LIE ANGLE	OFFSET (MM)	GRAPHITE LENGTH	GRAPHITE SHAFT FLEX	GRAPHITE SWING WEIGHT	GRAPHITE RH/LH	STEEL LENGTH	STEEL SHAFT FLEX	STEEL SWING WEIGHT	STEEL RH/LH
3U	19.0°	62.50°	3.2	37.25"	S, R	D1	RH	37.25"	S, R	D2	RH
4U	22.0°	62.50°	2.7	37.25"	S, R	D1	RH	37.25"	S, R	D2	RH
5U	25.0°	62.50°	3.3	37.25"	*S, *R	D1	*RH	37.25"	S, R	D2	*RH

*Custom only

3U & 4U available in stock graphite reg & stiff

3U & 4U available in stock reg & stiff steel

GRIP	SHAFT	COLORS
<ul style="list-style-type: none"> GRIP0196 Lamkin Crossline Black STD 58R (48g) - Red & Blue 	<ul style="list-style-type: none"> Graphite: MCA MMT Hybrid 80 (S, R) - 85g Steel: KBS S-Taper Lite (S, R - 110g)  	<ul style="list-style-type: none"> Chrome

The KING TEC Hybrid features a refined shape, H.O.T. Face Technology, and adjustable weighting and loft to deliver ultimate versatility in a better player hybrid.



H.O.T. FACE TECHNOLOGY

A H.O.T. Face design uses artificial intelligence to create a variable thickness pattern that delivers more efficient speed and spin across the face.

PWRSHELL FACE DESIGN

A forged PWRSHELL face insert delivers more flexibility across a larger area of the face for faster ball speed and higher launch.

LIGHTWEIGHT CARBON CROWN

A carbon crown allows more discretionary weight to be positioned within the clubhead to enhance speed and forgiveness.

ADJUSTABLE WEIGHTING SYSTEM



Two 12g heavy weights can be positioned in the toe, heel and front to fine tune trajectory and spin performance. Heavier 14g and lighter 10g weights are available in custom to allow for +4g and -4g in weight adjustment.



Free Arccos sensors with purchase

CLUB	LOFT & LIE SETTINGS									WEIGHT ADJUSTABILITY	LENGTH	SHAFT OFFERING / FLEX / SWING WEIGHT	RH/LH
	-1.5°	-1°	-1°D	STD°	STD°D	+1°	+1°D	+1.5°					
2H	15.5° (58.50°)	16.0° (57.80°)	16.0°D (59.20°)	17.0° (57.20°)	17.0°D (59.80°)	18.0° (57.80°)	18.0°D (59.20°)	18.5° (58.50°)		FRONT/BACK/HEEL	41.25"	MCA MMT 80 (S - 85g): D0.5	RH/*LH
3H	17.5° (59.00°)	18.0° (58.30°)	18.0°D (59.70°)	19.0° (57.70°)	19.0°D (60.30°)	20.0° (58.30°)	20.0°D (59.70°)	20.5° (59.00°)		FRONT/BACK/HEEL	40.50"	MCA MMT 80 (X - 88.5g, S - 85g), MMT 70 (R - 73g): D0.5	RH/*LH
4H	19.5° (59.50°)	20.0° (58.80°)	20.0°D (60.20°)	21.0° (58.20°)	21.0°D (60.80°)	22.0° (58.80°)	22.0°D (60.20°)	22.5° (59.50°)		FRONT/BACK/HEEL	39.75"	MCA MMT 80 (S - 85g), MMT 70 (R - 73g): D0.5	RH/*LH
5H	22.5° (60.00°)	23.0° (59.30°)	23.0°D (60.70°)	24.0° (58.70°)	24.0°D (61.30°)	25.0° (59.30°)	25.0°D (60.70°)	25.5° (60.00°)		FRONT/BACK/HEEL	39.00"	MCA MMT 70 (R - 73g): D0.5	RH

*LH custom only

GRIP	SHAFT	COLORS
<ul style="list-style-type: none"> GRIP0195 Lamkin Crossline Black STD 58R (48g) 	<ul style="list-style-type: none"> Graphite: MCA MMT Hybrid 80 (X, S), MCA MMT Hybrid 70 (R) 	<ul style="list-style-type: none"> Turbulence/Black

A new face milling pattern and SNAKEBITE grooves maximize spin control in both dry and wet conditions.



Free Arccos sensors with purchase



SNAKEBITE GROOVE TECHNOLOGY

An ultra precise CNC milled groove uses sharper edges and a larger groove volume to deliver maximum spin.

UPDATED FACE MILLING PATTERN

A new face milling pattern produces 50% more spin in wet conditions than the previous generation wedge.

FULL FACE GROOVES (56, 58, 60)

Full face grooves on the 56, 58, and 60 degree lofts provides maximum spin performance on shots with an open face.



3 GRINDS: VERSATILE, CLASSIC, WIDELOW

The "versatile" grind features toe, heel and trailing edge relief, the "classic" grind features a progressive sole width from heel to toe, and the "widelow" grind features a wide sole with reduced bounce.

PROGRESSIVE NOTCH DESIGN

A notch design enhances versatility by enabling the leading edge to sit flush with the turf on open shots. The notch is center-aligned on the 48-56 degree lofts and more heelward on the 58-60 degree lofts.

LOFT	BOUNCE	GRIND	LIE ANGLE	LENGTH	SWING WEIGHT	SHAFT FLEX	RH/LH
48.0°	8.0°	VERSATILE	64.00°	35.75"	D2	S	RH
50.0°	8.0°	VERSATILE	64.00°	35.75"	D2	S	RH
52.0°	8.0°	VERSATILE	64.00°	35.75"	D3	S	RH/LH
52.0°	12.0°	CLASSIC	64.00°	35.75"	D3	S	RH
54.0°	10.0°	VERSATILE	64.00°	35.50"	D4	S	RH
56.0°	7.0°	WIDELOW	64.00°	35.50"	D4	S	RH
56.0°	10.0°	VERSATILE	64.00°	35.50"	D4	S	RH/LH
56.0°	12.0°	CLASSIC	64.00°	35.50"	D4	S	RH
58.0°	6.0°	WIDELOW	64.00°	35.25"	D4	S	RH
58.0°	8.0°	VERSATILE	64.00°	35.25"	D4	S	RH
60.0°	4.0°	WIDELOW	64.00°	35.25"	D4	S	RH
60.0°	8.0°	VERSATILE	64.00°	35.25"	D4	S	RH/LH
60.0°	11.0°	CLASSIC	64.00°	35.25"	D4	S	RH

GRIP	SHAFT	COLORS
<ul style="list-style-type: none"> GRIP0195 Lamkin Crossline Black STD 58R (48g) 	<ul style="list-style-type: none"> Steel: KBS Hi-Rev 2.0 (125g) 	<ul style="list-style-type: none"> Chrome Black QPQ Tour Raw (Custom Only) available in March 2024

A ONE Length design improves consistency while delivering the same precise performance you'd expect from a specialty wedge.



ONE LENGTH CONFIGURATION

ONE Length delivers improved consistency and accuracy by encouraging one repeatable setup, ball position, and swing for shot around the green.

SNAKEBITE GROOVE TECHNOLOGY

An ultra precise CNC milled groove uses sharper edges and a larger groove volume to deliver maximum spin.

UPDATED FACE MILLING PATTERN

A new face milling pattern produces 50% more spin in wet conditions than the previous generation wedge.



PROGRESSIVE NOTCH DESIGN

A notch design enhances versatility by enabling the leading edge to sit flush with the turf on open shots. The notch is center-aligned on the 48-56 degree lofts and more heelward on the 58-60 degree lofts.



Free Arccos sensors with purchase

LOFT	BOUNCE	GRIND	LIE ANGLE	LENGTH	SWING WEIGHT	SHAFT FLEX	RH/LH
48.0°	8.0°	VERSATILE	61.50°	37.00"	D3.5	S	RH
52.0°	8.0°	VERSATILE	61.50°	37.00"	D3.5	S	RH/*LH
54.0°	10.0°	VERSATILE	61.50°	37.00"	D3.5	S	RH
56.0°	10.0°	VERSATILE	61.50°	37.00"	D3.5	S	RH/*LH
60.0°	8.0°	VERSATILE	61.50°	37.00"	D3.5	S	RH/*LH

GRIP	SHAFT	COLORS
<ul style="list-style-type: none"> GRIP0196 Lamkin Crossline Black STD 58R (48g) - Red & Blue 	<ul style="list-style-type: none"> Steel: KBS Hi-Rev 2.0 (125g)  <p>*Graphite available in custom only</p>	<ul style="list-style-type: none"> Chrome

A forgiving cavity back design enables you to step up your short game and play every specialty shot with more confidence.



SNAKEBITE GROOVE TECHNOLOGY

An ultra precise CNC milled groove uses sharper edges and a larger groove volume to deliver maximum spin.

HOLLOW DESIGN

An oversized hollow cavity back design provides extreme forgiveness and versatility

TPU INSERT

A TPU insert behind the sweet spot provides a cushiony feel on every swing.

UPDATED FACE MILLING PATTERN

A new face milling pattern produces 50% more spin in wet conditions than the previous generation wedge.

TEARDROP GRIND

A new teardrop shaped grind provides forgiveness and versatility out of every type of turf and bunker

FULL FACE GROOVES

Full face grooves provide consistent spin across the face





Free Arccos sensors with purchase

LOFT	BOUNCE	GRIND	LIE ANGLE	LENGTH	SWING WEIGHT	SHAFT FLEX	RH/LH
48.0°	10.0°	TEARDROP	65.00°	35.75"	D2	S	RH/*LH
50.0°	10.0°	TEARDROP	65.00°	35.75"	D2	S	RH/*LH
52.0°	10.0°	TEARDROP	65.00°	35.75"	D3	S	RH/*LH
54.0°	12.0°	TEARDROP	65.00°	35.50"	D4	S	RH/LH
56.0°	14.0°	TEARDROP	65.00°	35.50"	D4	S	RH/LH
58.0°	12.0°	TEARDROP	65.00°	35.25"	D4	S	RH/LH
60.0°	12.0°	TEARDROP	65.00°	35.25"	D4	S	RH/LH

*LH custom only

New 50.0°, 54.0°, and 58.0° loft additions available in March 2024

GRIP	SHAFT	COLORS
<ul style="list-style-type: none"> GRIP0195 Lamkin Crossline Black STD 58R (48g) 	<ul style="list-style-type: none"> Steel: KBS MAX 85 (102g)  <p>*Graphite available in custom only</p>	<ul style="list-style-type: none"> Chrome

IRON COMPARISON

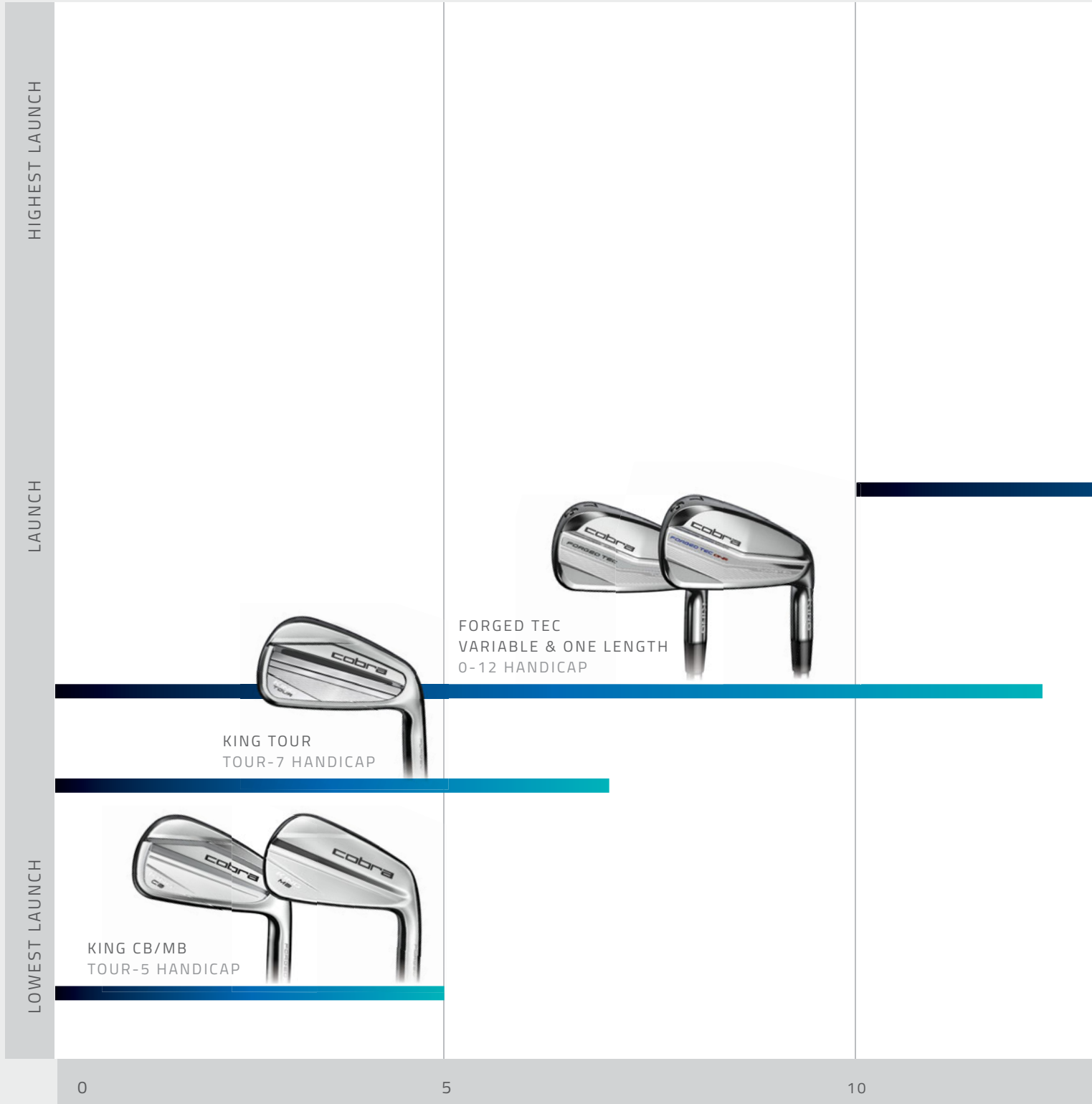

HIGHEST LAUNCH

LAUNCH

LOWEST LAUNCH

0

5

10

HANDICAP RANGE

KING TOUR
TOUR-7 HANDICAP

FORGED TEC
VARIABLE & ONE LENGTH
0-12 HANDICAP

KING CB/MB
TOUR-5 HANDICAP

FORGED TEC X
10-20 HANDICAP



DARKSPEED
VARIABLE & ONE LENGTH
10-20 HANDICAP



AIR-X
17+ HANDICAP



T-RAIL HYBRID-IRONS
17+ HANDICAP



MOST FORGIVING

FORGIVENESS

LEAST FORGIVING

15

20

25

HANDICAP RANGE



AIR X

EDGE

OFFSET

DR AW



LIGHTER. FASTER. EASIER.

AIR-X is our lightest weight product line suited for players with smoother swing tempos. A lightweight design enables easier speed creation to produce as much distance as possible, regardless of your age, strength, and swing mechanics.



Featuring a lightweight construction, and an all new H.O.T. Face insert, the AIR-X driver is designed to help golfers with smooth tempos generate increased club speed and distance.



LIGHTWEIGHT DESIGN

The combination of a lighter head, shaft, and grip encourages faster club speed.

H.O.T. FACE TECHNOLOGY

An A.I. designed variable thickness pattern increases forgiveness across the face.

DRAW-BIASED WEIGHTING

Weight is concentrated in the heel area to promote a draw-biased ball flight.

OFFSET DESIGN

An offset design provides maximum slice correction for a straighter ball flight.

AVAILABLE IN STRAIGHT NECK

A straight neck offering with no offset is available to those that prefer a traditional setup.

LOFTS				LIE ANGLE	WEIGHTING	LENGTH	SWING WEIGHT	SHAFT FLEX	RH/LH
OS:	9.5° (RH)	10.5° (RH/LH)	11.5° (RH)	61.00°	DRAW WEIGHT	46.00"	D1.5	S, R, A	RH/LH
SN:	9.5° (RH)	10.5° (RH/LH)							

GRIP	SHAFT	COLORS
<ul style="list-style-type: none"> GRIP0173 Lamkin EPDM REL Black STD 58R 	<ul style="list-style-type: none"> COBRA Ultralite 40 (50g) 	<ul style="list-style-type: none"> Matte Black With Red & Yellow Accents

Featuring a lightweight construction, and an all new H.O.T. Face insert, the AIR-X fairway is designed to help golfers with smooth tempos generate increased club speed and distance.



LIGHTWEIGHT DESIGN

The combination of a lighter head, shaft, and grip encourages faster club speed.

H.O.T. FACE TECHNOLOGY

An A.I. designed variable thickness pattern increases forgiveness across the face.

DRAW-BIASED WEIGHTING

Weight is concentrated in the heel area to promote a draw-biased ball flight.

OFFSET DESIGN

An offset design provides maximum slice correction for a straighter ball flight.

FAIRWAY	LOFT	WEIGHTING	LIE ANGLE	LENGTH	SWING WEIGHT	SHAFT FLEX	RH/LH
3W	16.0°	DRAW WEIGHTING	58.00°	43.00"	C9	S, R, A	RH/*LH
5W	19.0°	DRAW WEIGHTING	59.00°	42.50"	C9	S, R, A	RH/*LH
7W	22.0°	DRAW WEIGHTING	60.00°	42.00"	C9	R, A	RH

*LH custom only

GRIP	SHAFT	COLORS
<ul style="list-style-type: none"> GRIP0173 Lamkin EPDM REL Black STD 58R 	<ul style="list-style-type: none"> COBRA Ultralite 50 (55g) 	<ul style="list-style-type: none"> Matte Black With Red & Yellow Accents

Featuring a lightweight construction, and an all new H.O.T. Face insert, the AIR-X hybrid is designed to help golfers with smooth tempos generate increased club speed and distance.



LIGHTWEIGHT DESIGN

Using a lighter head, shaft and grip makes the club feel significantly lighter enabling faster clubhead speed without having to swing harder.

H.O.T. FACE TECHNOLOGY

An A.I. designed variable thickness pattern increases forgiveness across the face.

HEEL WEIGHTING

We positioned as much weight as possible in the heel of the club to make it easier to turn the club over for a straighter ball flight.

OFFSET DESIGN

An offset hosel helps to eliminate a slice and promotes a straighter ball flight.

CLUB	LOFT	LIE ANGLE	LENGTH	SWING WEIGHT	SHAFT FLEX	RH/LH
3H	19.0°	59.00°	40.50"	S, R, A	C7.5	RH/*LH
4H	21.0°	59.50°	39.75"	S, R, A	C7.5	RH/*LH
5H	24.0°	60.00°	39.00"	R, A	C7.5	RH/*LH
6H	27.0°	60.50°	38.50"	R, A	C7.5	RH/*LH
7H	30.0°	61.00°	38.00"	R, A	C7.5	RH

*Custom only

GRIP	SHAFT	COLORS
<ul style="list-style-type: none"> GRIP0173 Lamkin EPDM REL Black STD 58R 	<ul style="list-style-type: none"> COBRA Ultralite 50 (55g) 	<ul style="list-style-type: none"> Matte Black With Red & Yellow Accents

Featuring a lightweight construction, and an all new H.O.T. Face insert, the AIR-X irons are designed to help golfers with smooth tempos generate increased club speed and distance.



LIGHTWEIGHT DESIGN

The combination of a lighter head, shaft, and grip encourages faster club speed.

H.O.T. FACE TECHNOLOGY

An A.I. designed variable thickness pattern increases forgiveness across the face.

DRAW-BIASED WEIGHTING

Weight is concentrated in the heel area to promote a draw-biased ball flight.

OFFSET DESIGN

An offset design provides maximum slice correction for a straighter ball flight.

CLUB	LOFT	LIE ANGLE	OFFSET (MM)	LENGTH	GRAPHITE SWING WEIGHT	STEEL SWING WEIGHT	GRAPHITE SHAFT FLEX	STEEL SHAFT FLEX	RH/LH
4	21.0°	62.50°	7.6	39.25"	C6	D0	S, R, A	S, R	RH/LH
5	24.0°	62.50°	6.7	38.50"	C7	D0	S, R, A	S, R	RH/LH
6	27.0°	62.50°	5.9	37.75"	C7	D0	S, R, A	S, R	RH/LH
7	30.0°	62.50°	5.1	37.25"	C7	D0	S, R, A	S, R	RH/LH
8	34.0°	63.00°	4.4	36.75"	C7	D0	S, R, A	S, R	RH/LH
9	38.5°	63.50°	3.7	36.25"	C7	D0	S, R, A	S, R	RH/LH
PW	43.5°	64.00°	3.1	36.00"	C7	D0	S, R, A	S, R	RH/LH
GW	49.0°	64.00°	2.5	35.75"	C9	D1	S, R, A	S, R	RH/LH
SW	55.0°	64.00°	2.0	35.50"	C9	D1	S, R, A	S, R	RH/LH

STOCK SET COMPOSITION	GRIP	SHAFT	COLORS
Combo: 5H, 6H, 7-GW (GA - RH only), 4H, 5H, 6-PW (GR - RH only) Steel Irons: 5-GW (SR - RH only), 5S - RH only)	<ul style="list-style-type: none"> GRIP0173 Lamkin EPDM REL Black STD 58R 	<ul style="list-style-type: none"> Graphite: COBRA Ultralite 50 (58.5g - S, R, 56g - A) <ul style="list-style-type: none"> Steel: COBRA Ultralite Steel (111g) 	<ul style="list-style-type: none"> Silver With Black/Red/ Yellow Accents

Featuring a lightweight construction, and an all new H.O.T. Face insert, the AIR-X women's driver is designed to help golfers with smooth tempos generate increased club speed and distance.



LIGHTWEIGHT DESIGN

The combination of a lighter head, shaft, and grip encourages faster club speed.

H.O.T. FACE TECHNOLOGY

An A.I. designed variable thickness pattern increases forgiveness across the face.

DRAW-BIASED WEIGHTING

Weight is concentrated in the heel area to promote a draw-biased ball flight.

OFFSET DESIGN

An offset design provides maximum slice correction for a straighter ball flight.

LOFT	LIE ANGLE	WEIGHTING	LENGTH	SHAFT OFFERING	FLEX	SWING WEIGHT	RH/LH
11.5°	61.00°	DRAW WEIGHT	44.75"	COBRA Ultralite 45 (50g)	L	C6	RH
15.0°	61.00°	DRAW WEIGHT	44.75"	COBRA Ultralite 45 (50g)	L	C4	RH/LH

GRIP	SHAFT	COLORS
<ul style="list-style-type: none"> GRIP0174 Lamkin EPDM REL Black Undersize 60R 	<ul style="list-style-type: none"> COBRA Ultralite 45 (50g) 	<ul style="list-style-type: none"> Gloss Black With Cool Blue Accents

Featuring a lightweight construction, and an all new H.O.T. Face insert, the AIR-X women's fairway is designed to help golfers with smooth tempos generate increased club speed and distance.



LIGHTWEIGHT DESIGN

The combination of a lighter head, shaft, and grip encourages faster club speed.

H.O.T. FACE TECHNOLOGY

An A.I. designed variable thickness pattern increases forgiveness across the face.

DRAW-BIASED WEIGHTING

Weight is concentrated in the heel area to promote a draw-biased ball flight.

OFFSET DESIGN

An offset design provides maximum slice correction for a straighter ball flight.

FAIRWAY	LOFT	WEIGHTING	LIE ANGLE	LENGTH	SHAFT OFFERING	FLEX	SWING WEIGHT	RH/LH
3W	19.0°	DRAW WEIGHTING	59.00°	42.25"	COBRA Ultralite 45 (50g)	L	C3	RH/*LH
5W	22.0°	DRAW WEIGHTING	60.00°	41.75"	COBRA Ultralite 45 (50g)	L	C3	RH/*LH
7W	26.0°	DRAW WEIGHTING	61.00°	41.25"	COBRA Ultralite 45 (50g)	L	C3	RH

GRIP	SHAFT	COLORS
<ul style="list-style-type: none"> GRIP0174 Lamkin EPDM REL Black Undersize 60R 	<ul style="list-style-type: none"> COBRA Ultralite 45 (50g) 	<ul style="list-style-type: none"> Gloss Black With Cool Blue Accents

Featuring a lightweight construction, and an all new H.O.T. Face insert, the AIR-X women's hybrid is designed to help golfers with smooth tempos generate increased club speed and distance.



LIGHTWEIGHT DESIGN

Using a lighter head, shaft and grip makes the club feel significantly lighter enabling faster clubhead speed without having to swing harder.

H.O.T. FACE TECHNOLOGY

An A.I. designed variable thickness pattern increases forgiveness across the face.

HEEL WEIGHTING

We positioned as much weight as possible in the heel of the club to make it easier to turn the club over for a straighter ball flight.

OFFSET DESIGN

An offset hosel helps to eliminate a slice and promotes a straighter ball flight.

CLUB	LOFT	LIE ANGLE	LENGTH	SHAFT OFFERING	FLEX	SWING WEIGHT	RH/LH
4H	21.0°	59.50°	38.75"	COBRA Ultralite 45 (50g)	L	C2.5	RH/*LH
5H	24.0°	60.00°	38.00"	COBRA Ultralite 45 (50g)	L	C2.5	RH/*LH
6H	27.0°	60.50°	37.50"	COBRA Ultralite 45 (50g)	L	C2.5	RH/*LH
7H	30.0°	61.00°	37.00"	COBRA Ultralite 45 (50g)	L	C2.5	RH

*Custom only

GRIP	SHAFT	COLORS
<ul style="list-style-type: none"> GRIP0174 Lamkin EPDM REL Black Undersize 60R 	<ul style="list-style-type: none"> COBRA Ultralite 45 (50g) 	<ul style="list-style-type: none"> Gloss Black With Cool Blue Accents

Featuring a lightweight construction, and an all new H.O.T. Face insert, the AIR-X women's irons are designed to help golfers with smooth tempos generate increased club speed and distance.



LIGHTWEIGHT DESIGN

The combination of a lighter head, shaft, and grip encourages faster club speed.

H.O.T. FACE TECHNOLOGY

An A.I. designed variable thickness pattern increases forgiveness across the face.

DRAW-BIASED WEIGHTING

Weight is concentrated in the heel area to promote a draw-biased ball flight.

OFFSET DESIGN

An offset design provides maximum slice correction for a straighter ball flight.

CLUB	LOFT	LIE ANGLE	OFFSET (MM)	GRAPHITE LENGTH	GRAPHITE SWING WEIGHT	GRAPHITE SHAFT FLEX	RH/LH
5	24.0°	62.50°	6.7	37.75"	C2.5	L	RH/LH
6	27.0°	62.50°	5.9	37.00"	C2.5	L	RH/LH
7	30.0°	62.50°	5.1	36.50"	C2.5	L	RH/LH
8	34.0°	63.00°	4.4	36.00"	C2.5	L	RH/LH
9	38.5°	63.50°	3.7	35.50"	C2.5	L	RH/LH
PW	43.5°	64.00°	3.1	35.25"	C2.5	L	RH/LH
GW	49.0°	64.00°	2.5	35.00"	C3.5	L	RH/LH
SW	55.0°	64.00°	2.0	34.75"	C3.5	L	RH/LH

STOCK SET COMPOSITION	GRIP	SHAFT	COLORS
Combo: 5H, 6H, 7-PW, SW (RH only)	<ul style="list-style-type: none"> GRIP0174 Lamkin EPDM REL Black Undersize 60R 	<ul style="list-style-type: none"> COBRA ULTRALITE 45 - L (50g) 	<ul style="list-style-type: none"> Silver With Cool Blue Accents

The T-Rail combo set features a traditional hybrid shape blended with 6 hybrid-irons. The unique setup enables golfers to enjoy immediate improvement in launch, distance and consistency without having to make any adjustments to their swing.



H.O.T. FACE TECHNOLOGY

H.O.T. Face Technology uses artificial intelligence to design a variable thickness pattern that delivers more efficient speed and spin across the face.



BAFFLER RAILS

Baffle Rails allow the club to glide effortlessly through any turf condition, making a great shot outcome always possible.



HOLLOW CONSTRUCTION

A hollow design through the set gives every club the super power of hybrid-like launch and distance.

4 HYBRID IN THE SET



A 4-hybrid launches higher and is more forgiving than a 4-iron, making longer approach shots not just easier, but much more consistent.

T-RAIL HYBRID	LOFT	LIE ANGLE	GRAPHITE LENGTH	SHAFT OFFERING	FLEX	SWING WEIGHT	RH/LH
4H	20.0°	58.50°	39.75"	COBRA Ultralite 50	S, R, A	C8	RH/LH
5H	23.0°	59.00°	39.00"	COBRA Ultralite 50	S, R, A	C8	RH/LH
6H	26.0°	59.50°	38.50"	COBRA Ultralite 50	S, R, A	C8	RH/LH

*Hybrids sold in combo set only; 5H & 6H available in a combo set through custom

CLUB	LOFT	LIE ANGLE	OFFSET (MM)	GRAPHITE LENGTH	GRAPHITE SWING WEIGHT	*STEEL SWING WEIGHT	GRAPHITE SHAFT FLEX	*STEEL SHAFT FLEX	RH/LH
4	20.0°	61.00°	4.3	39.25"	C8	D1	R, A	S, R	RH/LH
5	23.0°	61.50°	3.8	38.50"	C8	D1	R, A	S, R	RH/LH
6	26.0°	62.00°	3.4	37.75"	C8	D1	R, A	S, R	RH/LH
7	29.0°	62.50°	3.0	37.25"	C8	D1	R, A	S, R	RH/LH
8	34.0°	63.00°	2.6	36.75"	C8	D1	R, A	S, R	RH/LH
9	39.0°	63.50°	2.2	36.25"	C8	D1	R, A	S, R	RH/LH
PW	44.0°	64.00°	1.8	36.00"	C8	D1	R, A	S, R	RH/LH
GW	50.0°	64.50°	1.4	35.75"	C8	D1	R, A	S, R	RH/LH
SW	56.0°	65.00°	1.0	35.50"	C8	D1	R, A	S, R	RH/LH

*Steel custom only / Graphite Stiff custom only

STOCK SET COMPOSITION	GRIP	SHAFT	COLORS
Graphite Combo: 4H, 5-PW (Reg, Lite)	<ul style="list-style-type: none"> GRIP0074 Lamkin Crossline Black STD 58R (50g) 	<ul style="list-style-type: none"> Graphite: COBRA Ultralite 50 (58.5g - S, R, 56g - A) Steel: COBRA Ultralite Steel (115g)  	<ul style="list-style-type: none"> Silver/Red

The T-Rail combo set features a traditional hybrid shape blended with 6 hybrid-irons. The unique setup enables golfers to enjoy immediate improvement in launch, distance and consistency without having to make any adjustments to their swing.



H.O.T. FACE TECHNOLOGY

H.O.T. Face Technology uses artificial intelligence to design a variable thickness pattern that delivers more efficient speed and spin across the face.

BAFFLER RAILS

Baffler Rails allow the club to glide effortlessly through any turf condition, making a great shot outcome always possible.

HOLLOW CONSTRUCTION

A hollow design through the set gives every club the super power of hybrid-like launch and distance.

4 HYBRID IN THE SET



A 4-hybrid launches higher and is more forgiving than a 4-iron, making longer approach shots not just easier, but much more consistent.

T-RAIL HYBRID	LOFT	LIE ANGLE	GRAPHITE LENGTH	SHAFT OFFERING	FLEX	SWING WEIGHT	RH/LH
4H	20.0°	58.50°	39.75"	COBRA Ultralite 45	L	C2	RH/LH
5H	23.0°	59.00°	39.00"	COBRA Ultralite 45	L	C2	RH/LH
6H	26.0°	59.50°	38.50"	COBRA Ultralite 45	L	C2	RH/LH

*Hybrids sold in combo set only; 4H & 6H available in a combo set through custom

CLUB	LOFT	LIE ANGLE	OFFSET (MM)	GRAPHITE LENGTH	GRAPHITE SWING WEIGHT	GRAPHITE SHAFT FLEX	RH/LH
5	23.0°	61.50°	3.8	37.50"	C2	L	RH/*LH
6	26.0°	62.00°	3.4	36.75"	C2	L	RH/*LH
7	29.0°	62.50°	3.0	36.25"	C2	L	RH/*LH
8	34.0°	63.00°	2.6	35.75"	C2	L	RH/*LH
9	39.0°	63.50°	2.2	35.25"	C2	L	RH/*LH
PW	44.0°	64.00°	1.8	35.00"	C2	L	RH/*LH
GW	50.0°	64.50°	1.4	34.75"	C2	L	RH/*LH
SW	56.0°	65.00°	1.0	34.50"	C2	L	RH/*LH

*LH Custom Only

STOCK SET COMPOSITION	GRIP	SHAFT	COLORS
Graphite Combo: 5H, 6-PW, SW	<ul style="list-style-type: none"> GRIP0074 Lamkin Crossline Black STD 58R (50g) 	<ul style="list-style-type: none"> COBRA Ultralite 45 (50g) 	<ul style="list-style-type: none"> Silver PVD/Pink

COBRA PUTTERS

3D PRINTED

The COBRA 3D PRINTED line is constructed for those seeking ultimate stability. Featuring high MOI designs that consist of three shapes: oversized blade (GRANDSPORT), oversized fang (SUPERNOVA) and our showcase mallet design (AGERA). Each model is available with select hosel configurations to fit your ideal stroke type. When next level stability is packaged with LA GOLF DESCENDING LOFT TECHNOLOGY, you will get launch consistency from stroke to stroke, with unparalleled end-over-end roll performance in the game.

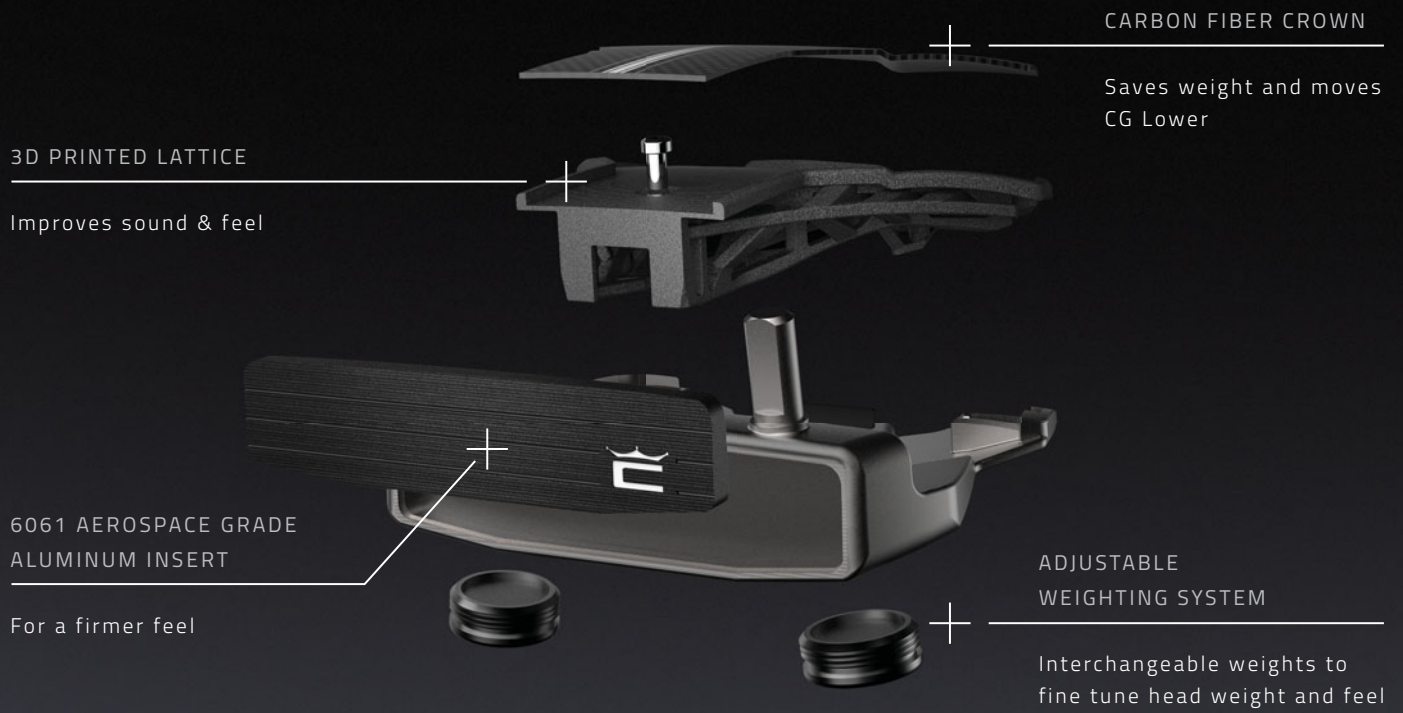

LA GOLF DESCENDING LOFT TECHNOLOGY

COBRA has licensed LA GOLF's patented DESCENDING LOFT TECHNOLOGY. Features four surface planes (4°, 3°, 2°, 1°) that mitigate the delofting or the addition of loft during head delivery at impact and provides consistent launch from putt-to-putt.



Vintage

The COBRA VINTAGE family blends classic designs with modern performance. Four classic shapes ranging from a blade (SPORT), an oversize blade (WIDESPOT), fang (NOVA) and oversized mallets (STINGRAY & CUDA) are created from a piece of MIM'd 304SS. A MIM construction delivers more consistency and accuracy while highlighting milled surfaces for enhanced appeal. Each putter features a new PEBAX insert that gives a soft and responsive feel while delivering unmatched roll performance with LA GOLF DESCENDING LOFT TECHNOLOGY.

PEBAX – THERMOPLASTIC ELASTOMER INSERT

For a softer, responsive feel

MIM 304 SS METAL

Precision with milled detail for premium look

ADJUSTABLE WEIGHTING SYSTEM

Interchangeable weights to fine tune head weight and feel

TRUER AND MORE CONSISTENT ROLL

DLT™ is designed to produce a consistent 1.5 degree launch angle regardless of how much shaft lean, attack angle, and whether the ball comes in contact on the higher or lower portion of the face.

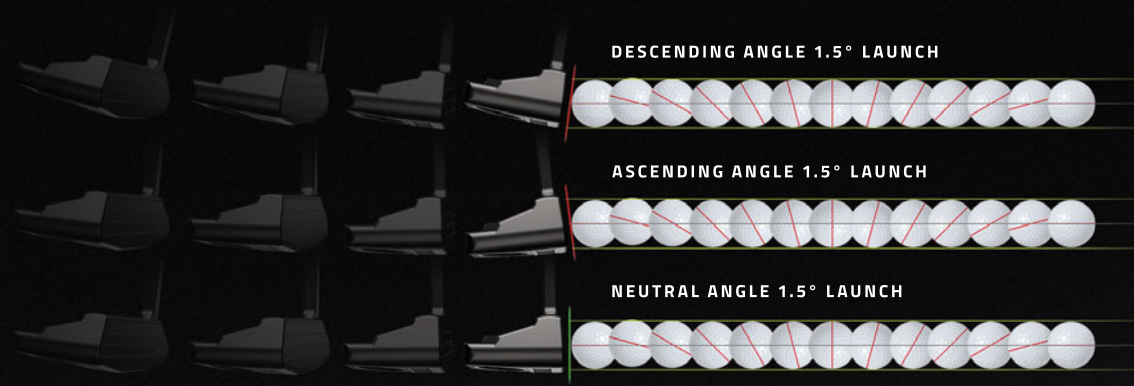

The COBRA GRANDSPORT-35 putter is a multi-material 3D printed construction that brings ultimate stability in a blade. Featuring a plumbers neck hosel, designed for players with a moderate arc stroke type. Paired with LA GOLF's Descending Loft Technology that delivers consistent launch and unmatched end-over-end roll performance in the market.



MULTI-MATERIAL CONSTRUCTION

An oversize blade shape combines a 3D printed nylon lattice cartridge-4g, a 304 stainless steel MIM frame-302g and a 3g carbon fiber crown that creates the ultimate design for stability.

3D PRINTED NYLON CARTRIDGE

An intricate 3D printed nylon lattice cartridge optimizes weight savings allowing CG to sit low and forward to optimize energy transfer and stability.

LA GOLF'S DESCENDING LOFT TECHNOLOGY

Featuring a 6061-aerospace grade aluminum insert with LA GOLF's proprietary Descending Loft Technology, utilizes 4 descending lofts (4°, 3°, 2°, 1°) to mitigate delofting and the addition of loft through head delivery during impact and provides an optimal launch for unparalleled end-over-end roll performance.



ADJUSTABLE WEIGHTING SYSTEM

Adjustable weighting system gives the player the ability to interchange to a lighter or heavier weight to achieve a personal feel. All putters ship stock with nominal 15g weights and can move +/- 5-10g in either direction. Additional weights sold separately. (5g, 10g, 15g, 20g, 25g)



Free Arccos sensors with purchase

HOSEL TYPE	TOE HANG	CUT LENGTH	HEAD WEIGHT	DESCENDING LOFT	LIE ANGLE	RH/LH
PLUMBER NECK	35°	34.00"	375g	4°, 3°, 2°, 1°	70°	RH
PLUMBER NECK	35°	35.00"	365g	4°, 3°, 2°, 1°	70°	RH/LH

GRIP	SHAFT	COLORS
<ul style="list-style-type: none"> Super Stroke ZENERGY GT 1.0 (83g) 	<ul style="list-style-type: none"> KBS CT TOUR 120 (124g) 	<ul style="list-style-type: none"> Charcoal Grey

The COBRA GRANDSPORT-Armlock putter is a multi-material 3D printed construction that brings ultimate stability in a blade. Featuring a plumbers neck hosel, designed for players with a moderate arc stroke type and seeking a longer armlock shaft setup. Paired with LA GOLF's Descending Loft Face Technology that delivers consistent launch and unmatched end-over-end roll performance in the market.



ARMLOCK DESIGN

An armlock setup increases consistency by eliminating any variations in shaft angle through the putting stroke. A longer length and an oversize grip allows the user to rest the grip and shaft against their lead forearm for maximum stability.

MULTI-MATERIAL CONSTRUCTION

An oversize blade shape combines a 3D printed nylon lattice cartridge-4g, a 304 stainless steel MIM frame-302g and a 3g carbon fiber crown that creates the ultimate design for stability.

3D PRINTED NYLON CARTRIDGE

An intricate 3D printed nylon lattice cartridge optimizes weight savings allowing CG to sit low and forward to optimize energy transfer and stability.

LA GOLF'S DESCENDING LOFT TECHNOLOGY

Featuring a 6061-aerospace grade aluminum insert with LA GOLF's proprietary Descending Loft Technology, utilizes 4 descending lofts (4°,3°,2°,1°) to mitigate delofting and the addition of loft through head delivery during impact and provides an optimal launch for unparalleled end-over-end roll performance.



ADJUSTABLE WEIGHTING SYSTEM

Adjustable weighting system gives the player the ability to interchange to a lighter or heavier weight to achieve a personal feel. All putters ship stock with nominal 15g weights and can move +- 5-10g in either direction. Additional weights sold separately. (5g, 10g, 15g, 20g, 25g)



Free Arccos sensors with purchase

HOSEL TYPE	TOE HANG	CUT LENGTH	HEAD WEIGHT	DESCENDING LOFT	LIE ANGLE	RH/LH
PLUMBERS NECK	45°	41.00"	390g	4°, 3°, 2°, 1°	76°	RH

GRIP	SHAFT	COLORS
<ul style="list-style-type: none"> Super Stroke ZENERGY GT 1.0 (83g) 	<ul style="list-style-type: none"> KBS CT TOUR 170 (170g) 	<ul style="list-style-type: none"> Charcoal Grey

The COBRA SUPERNOVA is a multi-material 3D printed construction that brings ultimate stability in a fang style putter shape. Featuring a single bend shaft designed for players with a straighter stroke type. Paired with LA GOLF's Descending Loft Face Technology that delivers consistent launch and unmatched end-over-end roll performance in the market.



MULTI-MATERIAL CONSTRUCTION

An oversize fang shape combines a 3D printed nylon lattice cartridge-17g, a 304 stainless steel MIM frame-294g and a 4g carbon fiber crown that creates the ultimate design for stability.

3D PRINTED NYLON CARTRIDGE

An intricate 3D printed nylon lattice cartridge optimizes weight savings allowing CG to sit low and forward to optimize energy transfer and stability.

LA GOLF'S DESCENDING LOFT TECHNOLOGY

Featuring a 6061-aerospace grade aluminum insert with LA GOLF's proprietary Descending Loft Technology, utilizes 4 descending lofts (4°, 3°, 2°, 1°) to mitigate delofting and the addition of loft through head delivery during impact and provides an optimal launch for unparalleled end-over-end roll performance.



ADJUSTABLE WEIGHTING SYSTEM

Adjustable weighting system gives the player the ability to interchange to a lighter or heavier weight to achieve a personal feel. All putters ship stock with nominal 15g weights and can move +/- 5-10g in either direction. Additional weights sold separately. (5g, 10g, 15g, 20g, 25g)



Free Arccos sensors with purchase

HOSEL TYPE	TOE HANG	CUT LENGTH	HEAD WEIGHT	DESCENDING LOFT	LIE ANGLE	RH/LH
SINGLE BEND	0°	34.00"	375g	4°, 3°, 2°, 1°	70°	RH
SINGLE BEND	0°	35.00"	365g	4°, 3°, 2°, 1°	70°	RH/LH

GRIP	SHAFT	COLORS
<ul style="list-style-type: none"> Super Stroke ZENERGY GT 1.0 (83g) 	<ul style="list-style-type: none"> KBS CT TOUR 120 (124g) 	<ul style="list-style-type: none"> Charcoal Grey

The COBRA AGERA putter is a multi-material 3D printed construction that brings ultimate stability in a flagship oversized mallet design. Featuring a single bend shaft designed for players with a straighter stroke type. Paired with LA GOLF's Descending Loft Face Technology that delivers consistent launch and unmatched end-over-end roll performance in the market.



MULTI-MATERIAL CONSTRUCTION

An oversize mallet shape combines a 3D printed nylon lattice cartridge-17g, a 304 stainless steel MIM frame-283g and a 7g carbon fiber crown that creates the ultimate design for stability.

3D PRINTED NYLON CARTRIDGE

An intricate 3D printed nylon lattice cartridge optimizes weight savings allowing CG to sit low and forward to optimize energy transfer and stability.

LA GOLF'S DESCENDING LOFT TECHNOLOGY

Featuring a 6061-aerospace grade aluminum insert with LA GOLF's proprietary Descending Loft Technology, utilizes 4 descending lofts (4°,3°,2°,1°) to mitigate delofting and the addition of loft through head delivery during impact and provides an optimal launch for unparalleled end-over-end roll performance.



ADJUSTABLE WEIGHTING SYSTEM

Adjustable weighting system gives the player the ability to interchange to a lighter or heavier weight to achieve a personal feel. All putters ship stock with nominal 15g weights and can move +- 5-10g in either direction. Additional weights sold separately. (5g, 10g, 15g, 20g, 25g)



Free Arccos sensors with purchase

HOSEL TYPE	TOE HANG	CUT LENGTH	HEAD WEIGHT	DESCENDING LOFT	LIE ANGLE	RH/LH
SINGLE BEND	0°	34.00"	375g	4°, 3°, 2°, 1°	70°	RH
SINGLE BEND	0°	35.00"	365g	4°, 3°, 2°, 1°	70°	RH/LH

GRIP	SHAFT	COLORS
<ul style="list-style-type: none"> Super Stroke ZENERGY GT 1.0 (83g) 	<ul style="list-style-type: none"> KBS CT TOUR 120 (124g) 	<ul style="list-style-type: none"> Charcoal Grey

The COBRA AGERA-Armlock putter is a multi-material 3D printed construction that brings ultimate stability in a flagship oversized mallet design. Featuring a plumbers neck hosel, designed for players with a moderate arc stroke type and seeking a longer armlock shaft setup. Paired with LA GOLF's Descending Loft Face Technology that delivers consistent launch and unmatched end-over-end roll performance in the market.



ARMLOCK DESIGN

An armlock setup increases consistency by eliminating any variations in shaft angle through the putting stroke. A longer length and an oversize grip allows the user to rest the grip and shaft against their lead forearm for maximum stability.

MULTI-MATERIAL CONSTRUCTION

An oversize mallet shape combines a 3D printed nylon lattice cartridge-17g, a 304 stainless steel MIM frame-283g and a 7g carbon fiber crown that creates the ultimate design for stability.

3D PRINTED NYLON CARTRIDGE

An intricate 3D printed nylon lattice cartridge optimizes weight savings allowing CG to sit low and forward to optimize energy transfer and stability.

LA GOLF'S DESCENDING LOFT TECHNOLOGY

Featuring a 6061-aerospace grade aluminum insert with LA GOLF's proprietary Descending Loft Technology, utilizes 4 descending lofts (4°,3°,2°,1°) to mitigate delofting and the addition of loft through head delivery during impact and provides an optimal launch for unparalleled end-over-end roll performance.



ADJUSTABLE WEIGHTING SYSTEM

Adjustable weighting system gives the player the ability to interchange to a lighter or heavier weight to achieve a personal feel. All putters ship stock with nominal 15g weights and can move +- 5-10g in either direction. Additional weights sold separately. (5g, 10g, 15g, 20g, 25g)



Free Arccos sensors with purchase

HOSEL TYPE	TOE HANG	CUT LENGTH	HEAD WEIGHT	DESCENDING LOFT	LIE ANGLE	RH/LH
PLUMBERS NECK	25°	41.00"	395g	4°, 3°, 2°, 1°	76°	RH

GRIP	SHAFT	COLORS
<ul style="list-style-type: none"> Super Stroke ZENERGY XL FLATSO 2.0 PLUS (78g) 	<ul style="list-style-type: none"> KBS CT TOUR 170 (170g) 	<ul style="list-style-type: none"> Charcoal Grey

The COBRA AGERA RS putter is a multi-material 3D printed construction that brings ultimate stability in a mallet design. Built on the chassis of the AGERA, but with a 15% smaller footprint, packs unparalleled performance for its size. Featuring a single bend shaft, designed for players with a straighter stroke type. Paired with LA GOLF's Descending Loft Face Technology that delivers consistent launch and unmatched end-over-end roll performance in the market.



MULTI-MATERIAL CONSTRUCTION

15% smaller profile than AGERA, combined with a 3D printed nylon lattice cartridge-13g, a 304 stainless steel MIM frame-293g and a 5g carbon fiber crown that creates the ultimate design for stability.

3D PRINTED NYLON CARTRIDGE

An intricate 3D printed nylon lattice cartridge optimizes weight savings allowing CG to sit low and forward to optimize energy transfer and stability.

LA GOLF'S DESCENDING LOFT TECHNOLOGY

Featuring a 6061-aerospace grade aluminum insert with LA GOLF's proprietary Descending Loft Technology, utilizes 4 descending lofts (4°, 3°, 2°, 1°) to mitigate delofting and the addition of loft through head delivery during impact and provides an optimal launch for unparalleled end-over-end roll performance.



ADJUSTABLE WEIGHTING SYSTEM

Adjustable weighting system gives the player the ability to interchange to a lighter or heavier weight to achieve a personal feel. All putters ship stock with nominal 15g weights and can move +- 5-10g in either direction. Additional weights sold separately. (5g, 10g, 15g, 20g, 25g)



Free Arccos sensors with purchase

HOSEL TYPE	TOE HANG	CUT LENGTH	HEAD WEIGHT	DESCENDING LOFT	LIE ANGLE	RH/LH
SINGLE BEND	0°	34.00"	375g	4°, 3°, 2°, 1°	70°	RH
SINGLE BEND	0°	35.00"	365g	4°, 3°, 2°, 1°	70°	RH/LH

GRIP	SHAFT	COLORS
<ul style="list-style-type: none"> Super Stroke ZENERGY GT 1.0 (83g) 	<ul style="list-style-type: none"> KBS CT TOUR 120 (124g) 	<ul style="list-style-type: none"> Charcoal Grey

The COBRA AGERA RS -30 putter is a multi-material 3D printed construction that brings ultimate stability in a mallet design. Built on the chassis of the AGERA, but with a 15% smaller footprint, packs unparalleled performance for its size. Featuring a slant neck hosel, designed for players with a moderate arc stroke type. Paired with LA GOLF's Descending Loft Face Technology that delivers consistent launch and unmatched end-over-end roll performance in the market.



MULTI-MATERIAL CONSTRUCTION

15% smaller profile than AGERA, combined with a 3D printed nylon lattice cartridge-13g, a 304 stainless steel MIM frame-293g and a 5g carbon fiber crown that creates the ultimate design for stability. an oversized mallet shape.

3D PRINTED NYLON CARTRIDGE

An intricate 3D printed nylon lattice cartridge optimizes weight savings allowing CG to sit low and forward to optimize energy transfer and stability.

LA GOLF's DESCENDING LOFT TECHNOLOGY

Featuring a 6061-aerospace grade aluminum insert with LA GOLF's proprietary Descending Loft Technology, utilizes 4 descending lofts (4°, 3°, 2°, 1°) to mitigate delofting and the addition of loft through head delivery during impact and provides an optimal launch for unparalleled end-over-end roll performance.



ADJUSTABLE WEIGHTING SYSTEM

Adjustable weighting system gives the player the ability to interchange to a lighter or heavier weight to achieve a personal feel. All putters ship stock with nominal 15g weights and can move +- 5-10g in either direction. Additional weights sold separately. (5g, 10g, 15g, 20g, 25g)



Free Arccos sensors with purchase

HOSEL TYPE	TOE HANG	CUT LENGTH	HEAD WEIGHT	DESCENDING LOFT	LIE ANGLE	RH/LH
SLANT NECK	30°	34.00"	375g	4°, 3°, 2°, 1°	70°	RH
SLANT NECK	30°	35.00"	365g	4°, 3°, 2°, 1°	70°	RH

GRIP	SHAFT	COLORS
<ul style="list-style-type: none"> Super Stroke ZENERGY GT 1.0 (83g) 	<ul style="list-style-type: none"> KBS CT TOUR 120 (124g) 	<ul style="list-style-type: none"> Charcoal Grey

The COBRA SPORT-40 putter is a timeless design in our VINTAGE series that blends classic shaping with modern performance. Featuring a plumbers neck hosel, designed for players with a moderate arc stroke type. Paired with LA GOLF's Descending Loft Face Technology that delivers consistent launch and unmatched end-over-end roll performance in the market.



CLASSIC BLADE SHAPE

A classic blade shape MIM'd from 304 stainless steel that features a classic single sightline for alignment at address.

SOFT PEBAX INSERT

Pebax is a high-performance thermoplastic elastomer (TPE) that offers an exceptional soft and responsive feel. Featuring LA GOLF's proprietary Descending Loft Technology, utilizes 4 descending lofts (4°, 3°, 2°, 1°) to mitigate delofting and the addition of loft through head delivery during the stroke and provides an optimal launch for unparalleled end-over-end roll performance.



ADJUSTABLE WEIGHTING SYSTEM

Adjustable weighting system gives the player the ability to interchange to a lighter or heavier weight to achieve a personal feel. All putters ship stock with nominal 15g weights and can move +/- 5-10g in either direction. Additional weights sold separately. (5g, 10g, 15g, 20g, 25g)



Free Arccos sensors with purchase

HOSEL TYPE	TOE HANG	CUT LENGTH	HEAD WEIGHT	DESCENDING LOFT	LIE ANGLE	RH/LH
PLUMBERS NECK	40°	34.00"	360g	4°, 3°, 2°, 1°	70°	RH
PLUMBERS NECK	40°	35.00"	350g	4°, 3°, 2°, 1°	70°	RH/LH

GRIP	SHAFT	COLORS
<ul style="list-style-type: none"> Super Stroke ZENERGY GT 1.0 (83g) 	<ul style="list-style-type: none"> KBS CT TOUR 120 (124g) 	<ul style="list-style-type: none"> Charcoal Grey

The COBRA SPORT-60 putter is a timeless design in our VINTAGE series that blends classic shaping with modern performance. Featuring a slant neck hosel, designed for players with a strong arc stroke type. Paired with LA GOLF's Descending Loft Face Technology that delivers consistent launch and unmatched end-over-end roll performance in the market.



CLASSIC BLADE SHAPE

A classic blade shape MIM'd from 304 stainless steel that features a classic single sightline for alignment at address.

SOFT PEBAX INSERT

Pebax is a high-performance thermoplastic elastomer (TPE) that offers an exceptional soft and responsive feel. Featuring LA GOLF's proprietary Descending Loft Technology, utilizes 4 descending lofts (4°, 3°, 2°, 1°) to mitigate delofting and the addition of loft through head delivery during the stroke and provides an optimal launch for unparalleled end-over-end roll performance.



ADJUSTABLE WEIGHTING SYSTEM

Adjustable weighting system gives the player the ability to interchange to a lighter or heavier weight to achieve a personal feel. All putters ship stock with nominal 15g weights and can move +/- 5-10g in either direction. Additional weights sold separately. (5g, 10g, 15g, 20g, 25g)



Free Arccos sensors with purchase

HOSEL TYPE	TOE HANG	CUT LENGTH	HEAD WEIGHT	DESCENDING LOFT	LIE ANGLE	RH/LH
FLOW NECK	60°	34.00"	360g	4°, 3°, 2°, 1°	70°	RH
FLOW NECK	60°	35.00"	350g	4°, 3°, 2°, 1°	70°	RH

GRIP	SHAFT	COLORS
<ul style="list-style-type: none"> Super Stroke ZENERGY GT 1.0 (83g) 	<ul style="list-style-type: none"> KBS CT TOUR 120 (124g) 	<ul style="list-style-type: none"> Charcoal Grey

The COBRA WIDESPOT putter blends classic shaping with modern performance in a chunkier blade profile. Featuring a single bend shaft, designed for players with a straighter stroke type. Paired with LA GOLF's Descending Loft Face Technology that delivers consistent launch and unmatched end-over-end roll performance in the market.



CLASSIC BLADE SHAPE

A classic blade shape MIM'd from 304 stainless steel that features a classic single sightline for alignment at address.

SOFT PEBAX INSERT

Pebax is a high-performance thermoplastic elastomer (TPE) that offers an exceptional soft and responsive feel. Featuring LA GOLF's proprietary Descending Loft Technology, utilizes 4 descending lofts (4°, 3°, 2°, 1°) to mitigate delofting and the addition of loft through head delivery during the stroke and provides an optimal launch for unparalleled end-over-end roll performance.



ADJUSTABLE WEIGHTING SYSTEM

Adjustable weighting system gives the player the ability to interchange to a lighter or heavier weight to achieve a personal feel. All putters ship stock with nominal 15g weights and can move +/- 5-10g in either direction. Additional weights sold separately. (5g, 10g, 15g, 20g, 25g)



Free Arccos sensors with purchase

HOSEL TYPE	TOE HANG	CUT LENGTH	HEAD WEIGHT	DESCENDING LOFT	LIE ANGLE	RH/LH
SINGLE BEND	0°	34.00"	370g	4°, 3°, 2°, 1°	70°	RH
SINGLE BEND	0°	35.00"	360g	4°, 3°, 2°, 1°	70°	RH

GRIP	SHAFT	COLORS
<ul style="list-style-type: none"> Super Stroke ZENERGY GT 1.0 (83g) 	<ul style="list-style-type: none"> KBS CT TOUR 120 (124g) 	<ul style="list-style-type: none"> Charcoal Grey

The COBRA NOVA putter blends classic shaping with modern performance in a fang design. Featuring a single bend shaft, designed for players with a straighter stroke type. Paired with LA GOLF's Descending Loft Face Technology that delivers consistent launch and unmatched end-over-end roll performance in the market.



CLASSIC FANG SHAPE

A fang shape is MIM'd from 304 stainless steel and features a triple sightline that frames up the golf ball for enhanced alignment at address.

SOFT PEBAX INSERT

Pebax is a high-performance thermoplastic elastomer (TPE) that offers an exceptional soft and responsive feel. Featuring LA GOLF's proprietary Descending Loft Technology, utilizes 4 descending lofts (4°, 3°, 2°, 1°) to mitigate delofting and the addition of loft through head delivery during the stroke and provides an optimal launch for unparalleled end-over-end roll performance.

ADJUSTABLE WEIGHTING SYSTEM

Adjustable weighting system gives the player the ability to interchange to a lighter or heavier weight to achieve a personal feel. All putters ship stock with nominal 15g weights and can move +- 5-10g in either direction. Additional weights sold separately. (5g, 10g, 15g, 20g, 25g)



Free Arccos sensors with purchase

HOSEL TYPE	TOE HANG	CUT LENGTH	HEAD WEIGHT	DESCENDING LOFT	LIE ANGLE	RH/LH
SINGLE BEND	0°	34.00"	360g	4°, 3°, 2°, 1°	70°	RH/LH
SINGLE BEND	0°	35.00"	350g	4°, 3°, 2°, 1°	70°	RH/LH

GRIP	SHAFT	COLORS
<ul style="list-style-type: none"> Super Stroke ZENERGY GT 1.0 (83g) 	<ul style="list-style-type: none"> KBS CT TOUR 120 (124g) 	<ul style="list-style-type: none"> Charcoal Grey

The COBRA NOVA-30 putter blends classic shaping with modern performance in a fang design. Featuring a slant neck hosel, designed for players with a moderate arc stroke type. Paired with LA GOLF's Descending Loft Face Technology that delivers consistent launch and unmatched end-over-end roll performance in the market.



CLASSIC FANG SHAPE

A fang shape is MIM'd from 304 stainless steel and features a triple sightline that frames up the golf ball for enhanced alignment at address.

SOFT PEBAX INSERT

Pebax is a high-performance thermoplastic elastomer (TPE) that offers an exceptional soft and responsive feel. Featuring LA GOLF's proprietary Descending Loft Technology, utilizes 4 descending lofts (4°, 3°, 2°, 1°) to mitigate delofting and the addition of loft through head delivery during the stroke and provides an optimal launch for unparalleled end-over-end roll performance.



ADJUSTABLE WEIGHTING SYSTEM

Adjustable weighting system gives the player the ability to interchange to a lighter or heavier weight to achieve a personal feel. All putters ship stock with nominal 15g weights and can move +/- 5-10g in either direction. Additional weights sold separately. (5g, 10g, 15g, 20g, 25g)



Free Arccos sensors with purchase

HOSEL TYPE	TOE HANG	CUT LENGTH	HEAD WEIGHT	DESCENDING LOFT	LIE ANGLE	RH/LH
SLANT NECK	30°	34.00"	360g	4°, 3°, 2°, 1°	70°	RH
SLANT NECK	30°	35.00"	350g	4°, 3°, 2°, 1°	70°	RH

GRIP	SHAFT	COLORS
<ul style="list-style-type: none"> Super Stroke ZENERGY GT 1.0 (83g) 	<ul style="list-style-type: none"> KBS CT TOUR 120 (124g) 	<ul style="list-style-type: none"> Charcoal Grey

The COBRA STINGRAY putter blends classic shaping with modern performance in a oversized mallet design. Featuring a single bend shaft, designed for players with a straighter stroke type. Paired with LA GOLF's Descending Loft Face Technology that delivers consistent launch and unmatched end-over-end roll performance in the market.



CLASSIC OVERSIZE MALLET SHAPE

An oversized mallet shape is MIM'd from 304 stainless steel and features a single long sightline for improved alignment at address.

SOFT PEBAX INSERT

Pebax is a high-performance thermoplastic elastomer (TPE) that offers an exceptional soft and responsive feel. Featuring LA GOLF's proprietary Descending Loft Technology, utilizes 4 descending lofts (4°, 3°, 2°, 1°) to mitigate delofting and the addition of loft through head delivery during the stroke and provides an optimal launch for unparalleled end-over-end roll performance.



ADJUSTABLE WEIGHTING SYSTEM

Adjustable weighting system gives the player the ability to interchange to a lighter or heavier weight to achieve a personal feel. All putters ship stock with nominal 15g weights and can move +/- 5-10g in either direction. Additional weights sold separately. (5g, 10g, 15g, 20g, 25g)



Free Arccos sensors with purchase

HOSEL TYPE	TOE HANG	CUT LENGTH	HEAD WEIGHT	DESCENDING LOFT	LIE ANGLE	RH/LH
SINGLE BEND	0°	34.00"	355g	4°, 3°, 2°, 1°	70°	RH
SINGLE BEND	0°	35.00"	350g	4°, 3°, 2°, 1°	70°	RH/LH

GRIP	SHAFT	COLORS
<ul style="list-style-type: none"> Super Stroke ZENERGY GT 1.0 (83g) 	<ul style="list-style-type: none"> KBS CT TOUR 120 (124g) 	<ul style="list-style-type: none"> Charcoal Grey

The COBRA STINGRAY -30 putter blends classic shaping with modern performance in a oversized mallet design. Featuring a slant neck hosel, designed for players with a moderate arc stroke type. Paired with LA GOLF's Descending Loft Face Technology that delivers consistent launch and unmatched end-over-end roll performance in the market.



CLASSIC OVERSIZE MALLET SHAPE

An oversized mallet shape is MIM'd from 304 stainless steel and features a single long sightline for improved alignment at address.

SOFT PEBAX INSERT

Pebax is a high-performance thermoplastic elastomer (TPE) that offers an exceptional soft and responsive feel. Featuring LA GOLF's proprietary Descending Loft Technology, utilizes 4 descending lofts (4°, 3°, 2°, 1°) to mitigate delofting and the addition of loft through head delivery during the stroke and provides an optimal launch for unparalleled end-over-end roll performance.



ADJUSTABLE WEIGHTING SYSTEM

Adjustable weighting system gives the player the ability to interchange to a lighter or heavier weight to achieve a personal feel. All putters ship stock with nominal 15g weights and can move +/- 10g in either direction. Additional weights sold separately. (5g, 10g, 15g, 20g, 25g)



Free Arccos sensors with purchase

HOSEL TYPE	TOE HANG	CUT LENGTH	HEAD WEIGHT	DESCENDING LOFT	LIE ANGLE	RH/LH
SLANT NECK	30°	34.00"	355g	4°, 3°, 2°, 1°	70°	RH
SLANT NECK	30°	35.00"	350g	4°, 3°, 2°, 1°	70°	RH

GRIP	SHAFT	COLORS
<ul style="list-style-type: none"> Super Stroke ZENERGY GT 1.0 (83g) 	<ul style="list-style-type: none"> KBS CT TOUR 120 (124g) 	<ul style="list-style-type: none"> Charcoal Grey

The COBRA CUDA putter blends classic shaping with modern performance in a hollow shell mallet design. Featuring a single bend shaft, designed for players with a straighter stroke type. Paired with LA GOLF's Descending Loft Face Technology that delivers consistent launch and unmatched end-over-end roll performance in the market.



CLASSIC OVERSIZE MALLET SHAPE

A hollow mallet shape MIM'd from 304 stainless steel and features a triple sightline that frames up the golf ball for enhanced alignment at address.

SOFT PEBAX INSERT

Pebax is a high-performance thermoplastic elastomer (TPE) that offers an exceptional soft and responsive feel. Featuring LA GOLF's proprietary Descending Loft Technology, utilizes 4 descending lofts (4°, 3°, 2°, 1°) to mitigate delofting and the addition of loft through head delivery during the stroke and provides an optimal launch for unparalleled end-over-end roll performance.



ADJUSTABLE WEIGHTING SYSTEM

Adjustable weighting system gives the player the ability to interchange to a lighter or heavier weight to achieve a personal feel. All putters ship stock with nominal 15g weights and can move +- 5-10g in either direction. Additional weights sold separately. (5g, 10g, 15g, 20g, 25g)



Free Arccos sensors with purchase

HOSEL TYPE	TOE HANG	CUT LENGTH	HEAD WEIGHT	DESCENDING LOFT	LIE ANGLE	RH/LH
SINGLE BEND	0°	34.00"	375g	4°, 3°, 2°, 1°	70°	RH
SINGLE BEND	0°	35.00"	365g	4°, 3°, 2°, 1°	70°	RH/LH

GRIP	SHAFT	COLORS
<ul style="list-style-type: none"> Super Stroke ZENERGY GT 1.0 (83g) 	<ul style="list-style-type: none"> KBS CT TOUR 120 (124g) 	<ul style="list-style-type: none"> Charcoal Grey

FASTER ← FACE CLOSURE → SLOWER



STRAIGHT STROKE	MODERATE ARC	STRONGER ARC
AGERA	AGERA ARMLOCK	GRANDSPORT ARMLOCK
AGERA RS	AGERA RS-30	SPORT-40
SUPERNOVA	GRANDSPORT-30	SPORT-60
WIDESPOT	STINGRAY-30	
STINGRAY	NOVA-30	
NOVA		
CUDA		



PLAY SMARTER WITH ARCCOS CADDIE

Experience automatic shot tracking Powered by Arccos Golf®. The A.I. platform features Arccos Caddie Rangefinder, Smart Distances, Strokes Gained Analytics, and Caddie Advice to help all golfers make smarter decisions, improve faster and shoot lower scores. With the purchase of any COBRA club, you are eligible for free Arccos Smart Sensors to equip your set and a free trial of the award-winning Arccos Caddie app.

ARCCOS CADDIE APP FEATURES

Arccos Caddie leverages data such as personal shot history, wind speed and direction, and elevation changes, and more to help players make smarter decisions on course and perform their best.



Automatic Shot Tracking

Smart Distance

A.I. Caddie Advice

Strokes Gained Analytics

Arccos Rangefinder





cobra

COMPLETE SETS



MEN'S SET

The AIR-X set features a 12-piece set of the same AIR-X clubs that are sold as separates with the exception of a non-PVD sole. Each club features a lightweight construction, and an all new H.O.T. Face insert, designed to help golfers with smooth tempos generate increased club speed and distance. The set also comes equipped with a premium blade putter, cart bag, and headcovers.

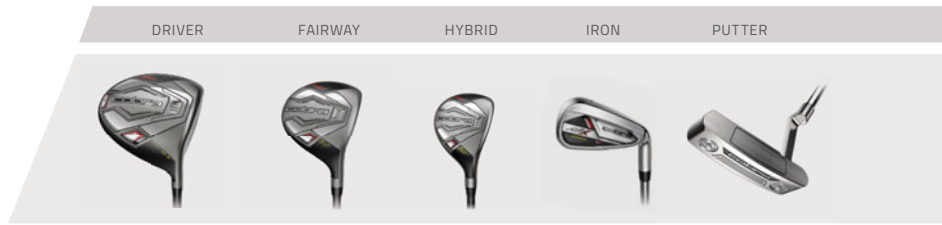

AIR-X DRIVER

An offset driver features a lightweight construction, and a new H.O.T. Face design, delivering the best combination of speed and forgiveness.

AIR-X FAIRWAY

A 3-wood features a shallow profile, an offset design, and heel biased weighting for easy launch and accuracy.

AIR-X HYBRIDS

A 4 and 5 hybrid with an offset design and heel-biased weighting make longer approach shots easier and more accurate than ever.

AIR-X IRONS

Low profile irons with greater lofts and perimeter weighting launch high and straight for more GIR's and birdie opportunities.

BLADE PUTTER

A premium blade putter design features a machined face for exceptional feel and control on long and short putts.

PREMIUM CART BAG

To tie the set together, a premium bag features a 14-way top, 9 zippered compartments, and a large insulated beverage cooler.

CLUB	LOFT	LIE ANGLE	GRAPHITE LENGTH	GRAPHITE SWING WEIGHT	GRAPHITE FLEX	STEEL SWING WEIGHT	STEEL FLEX	RH/LH
DRIVER	10.5° (Reg), 11.5° (Lite)	61.00°	46.00"	D1.5	R, A			RH
3W	16.0°	58.00°	43.00"	C9	R, A			RH
4H	21.0°	59.50°	39.75"	C7.5	R, A			RH
5H	25.0°	60.00°	39.00"	C8	R, A			RH
6	27.0°	62.50°	37.75"	C7	R, A	D0	R	RH
7	30.0°	62.50°	37.25"	C7	R, A	D0	R	RH
8	34.0°	63.00°	36.75"	C7	R, A	D0	R	RH
9	38.5°	63.50°	36.25"	C7	R, A	D0	R	RH
PW	43.5°	64.00°	36.00"	C7	R, A	D0	R	RH
SW	55.0°	64.00°	35.75"	C9	R, A	D0	R	RH
BLADE PUTTER	3.0°	70.00°	34.25"	-	-	-	-	RH

STOCK SET COMPOSITION	GRIP	SHAFT	COLOR
11 Clubs + Bag: Dr, 3W, 4H, 5H, 6-PW, SW, Putter, Cart Bag (Graphite Reg, Lite, and Steel Reg)	<ul style="list-style-type: none"> Lamkin REL Standard (58R) - Black 	<ul style="list-style-type: none"> Cobra Ultralite 40 (Driver) Cobra Ultralite 50 (Fwy, Hyb, Iron) 	<ul style="list-style-type: none"> Metals: Matte Black Crown With Non PVD Sole & Red Accents Irons: Silver Finish With Red Accents



WOMEN'S SET

The AIR-X women's set features a 12-piece set of the same AIR-X clubs that are sold as separates with the exception of a non-PVD sole. Each club features a lightweight construction, and an all new H.O.T. Face insert, designed to help golfers with smooth tempos generate increased club speed and distance. The set also comes equipped with a premium blade putter, cart bag, and headcovers.

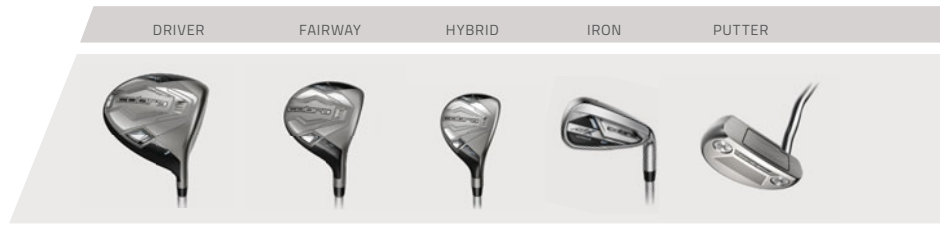

AIR-X DRIVER

An offset driver features a lightweight construction, and a new H.O.T. Face design, delivering the best combination of speed and forgiveness.

AIR-X FAIRWAY

A 3-wood and a 5-wood features a shallow profile, an offset design, and heel biased weighting for easy launch and accuracy.

AIR-X HYBRIDS

A 5 hybrid with an offset design and heel-biased weighting make longer approach shots easier and more accurate than ever.

AIR-X IRONS

Low profile irons with greater lofts and perimeter weighting launch high and straight for more GIR's and birdie opportunities.

MALLET PUTTER

A premium mallet putter design features a machined face for exceptional feel and control on long and short putts.

PREMIUM CART BAG

To tie the set together, a premium bag features a 14-way top, 9 zippered compartments, and a large insulated beverage cooler.

CLUB	LOFT	LIE ANGLE	GRAPHITE LENGTH	GRAPHITE SWING WEIGHT	GRAPHITE FLEX	RH/LH
DRIVER	15.0°	61.00°	44.75"	C5	LADIES	RH
3W	19.0°	59.00°	42.25"	C3	LADIES	RH
5W	22.0°	60.00°	41.75"	C3	LADIES	RH
5H	24.0°	60.00°	38.00"	C2.5	LADIES	RH
6	27.0°	62.50°	37.00"	C2.5	LADIES	RH
7	30.0°	62.50°	36.50"	C2.5	LADIES	RH
8	34.0°	63.00°	36.00"	C2.5	LADIES	RH
9	38.5°	63.50°	35.50"	C2.5	LADIES	RH
PW	43.5°	64.00°	35.25"	C3.5	LADIES	RH
SW	55.0°	64.00°	34.75"	C3.5	LADIES	RH
MALLET PUTTER	3.0°	70.00°	33.25"	-	-	RH

STOCK SET COMPOSITION	GRIP	SHAFT	COLOR
11 Club + Bag: Dr, 3W, 5W, 5H, 6-PW, SW, Putter, Cart Bag	<ul style="list-style-type: none"> Lamkin REL Undersize (60R) - Black 	<ul style="list-style-type: none"> Cobra Ultralite 40 (Driver) Cobra Ultralite 45 (Fwy, Hyb, Iron) 	<ul style="list-style-type: none"> Metals: Gloss Black Crown With Non PVD Sole & Cool Blue Accents Irons: Silver Finish With Cool Blue Accents

cobra FLY-XL

MEN'S SET

The Cobra FLY-XL complete set includes a full bag of lightweight and forgiving clubs that deliver easy launch and distance.



Black/Blue

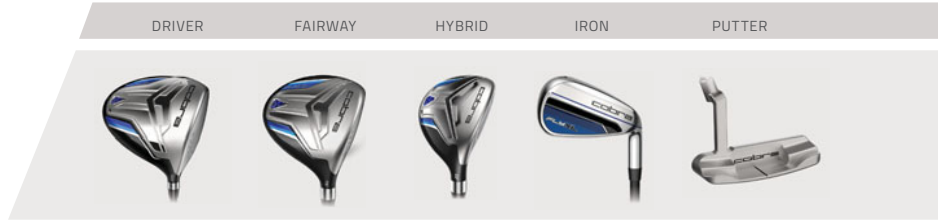

DRIVER

A titanium driver (10.5° in reg, and 11.5° in lite flex) has an oversized shape and heel-biased weighting for longer straighter drives.

FAIRWAY

A 3-wood and 5-wood feature a shallow profile and heel biased weighting for accuracy and distance off the tee and from the fairway.

HYBRIDS

A 4 and 5 hybrid create perfect gapping between the fairways and irons for longer approach shots into greens.

IRONS

The irons (6-PW, SW) have a traditional cavity back design and perimeter weighting for effortless launch and distance.



BLADE PUTTER

A premium blade putter design features a machined face for exceptional feel and control on long and short putts.

PREMIUM CART BAG

To tie the set together, a premium bag features a 14-way top, a velour valuables pocket, and 7 zippered compartments.

CLUB	LOFT	LIE ANGLE	GRAPHITE LENGTH	STEEL LENGTH	GRAPHITE SWING WEIGHT	STEEL SWING WEIGHT	GRAPHITE FLEX	STEEL FLEX	RH/LH
DRIVER	10.5° (Reg), 11.5° (Lite)	58.50°	45.50"	-	D2	-	R/LITE	-	RH/LH
3W	14.5°	58.00°	43.50"	-	D1	-	R/LITE	-	RH/LH
5W	18.5°	59.00°	43.00"	-	D1	-	R/LITE	-	RH/LH
4H	20.5°	59.00°	39.50"	-	D0	-	R/LITE	-	RH/LH
5H	23.5°	59.50°	38.75"	-	D0	-	R/LITE	-	RH/LH
6	26.0°	62.00°	37.75"	37.75"	C9	D2	R/LITE	R	RH/LH
7	30.0°	62.50°	37.25"	37.25"	C9	D2	R/LITE	R	RH/LH
8	35.0°	63.00°	36.75"	36.75"	C9	D2	R/LITE	R	RH/LH
9	40.0°	63.50°	36.25"	36.25"	C9	D2	R/LITE	R	RH/LH
PW	45.0°	64.00°	36.00"	36.00"	D0	D3	R/LITE	R	RH/LH
SW	55.0°	64.00°	35.50"	35.50"	D1	D3	R/LITE	R	RH/LH
BLADE PUTTER	3.0°	70.00°	34.25"	34.25"	-	-	R/LITE	R	RH/LH

STOCK SET COMPOSITION	GRIP	SHAFT	COLOR
12 Club + Bag: Dr, 3W, 5W, 4H, 5H, 6-PW, SW, Putter, Cart Bag Graphite Reg & Lite Flex Steel Reg Flex	<ul style="list-style-type: none"> Lamkin Crossline Black STD 58R (50g) 	<ul style="list-style-type: none"> Cobra Fly-XL Graphite (63g uncut) Cobra FLY-XL Steel (111g)  	<ul style="list-style-type: none"> Black/Blue

cobra[®] FLY-XL WOMEN'S SET

The Cobra FLY-XL women's complete set includes a full bag of lightweight and forgiving clubs that deliver easy launch and distance.



Silver/Plum

Black/Olive

DRIVER FAIRWAY HYBRID IRON PUTTER



DRIVER

A titanium driver (12.5*) has an oversized shape and heel-biased weighting for longer straighter drives.

FAIRWAY

A 3-wood, 5-wood and 7-wood feature a shallow profile and heel biased weighting for accuracy and distance off the tee and from the fairway.

HYBRIDS

A 5 hybrid creates perfect gapping between the fairways and irons for longer approach shots into greens.

IRONS

The irons (6-PW, SW) have a traditional cavity back design and perimeter weighting for effortless launch and distance.



MALLET PUTTER

A premium mallet putter design features a machined face for exceptional feel and control on long and short putts.

PREMIUM CART BAG

To tie the set together, a premium bag features a 14-way top, a velour valuables pocket, and 7 zippered compartments.

CLUB	LOFT	LIE ANGLE	GRAPHITE LENGTH (STD/*PETITE)	GRAPHITE SWING WEIGHT (STD/*PETITE)	GRAPHITE FLEX	RH/LH
DRIVER	12.5°	58.50°	44.50"	C7	LADIES	RH
3W	18.5°	59.00°	42.25"	C7	LADIES	RH
5W	21.5°	59.50°	41.75"	C7	LADIES	RH
7W	24.5°	60.00°	41.25"	C7	LADIES	RH
5H	23.5°	59.50°	37.75"	C5.5	LADIES	RH
6	26.0°	62.00°	36.75"	C3.5	LADIES	RH
7	30.0°	62.50°	36.25"	C3.5	LADIES	RH
8	35.0°	63.00°	35.75"	C3.5	LADIES	RH
9	40.0°	63.50°	35.25"	C3.5	LADIES	RH
PW	45.0°	64.00°	35.00"	C4.5	LADIES	RH
SW	55.0°	64.00°	34.50"	C4.5	LADIES	RH
MALLET	3.0°	70.00°	33.25"	-	LADIES	RH

STOCK SET COMPOSITION	GRIP	SHAFT	COLOR
12 Clubs + Bag: Dr, 3W, 5W, 7W, 5H, 6-PW, SW, Putter, Cart Bag	<ul style="list-style-type: none"> Lamkin Crossline Black STD 58R (50g) 	<ul style="list-style-type: none"> Cobra Fly-XL Graphite (63g uncut) 	<ul style="list-style-type: none"> Black/Olive Silver/Plum



cobra.



ACCESSORIES



ALL-NEW COBRA GOLF TRAVEL GEAR

The ultimate travel necessity utilizing durable nylon material with new roller wheels designed for smoother movements and versatility. Pops of details include debossed Crown C, leather Crown C zipper pullers, and internal mesh storage to travel with your game.

ULTRALIGHT PRO STAND BAG

A true lightweight carry bag. Gives golfers exactly what they need, in a comfortable, sleek package.



SMALL CROWN CAP

Using our lightweight tech based material for ultimate performance and breathability. Featuring a Cobra Crown C script embroidery and moisture wicking sweatband for maximum comfort while playing your best.



01 Puma Black



01 Puma Black



01 Puma Black

02 Bright White

COBRA TOUR STAND BAG 24' \$450

STYLE	WEIGHT	MATERIAL	POCKETS
909700	6 lbs	Shell: 100% Polyurethane Lining: 100% Polyester	6

- Cobra x Vessel Collaboration
- Tour Validated Stand Bag Offers Premium Versatility and Performance
- 4-way Top with Full Length Club Dividers
- Oversized Apparel Pocket
- Fleece Lined Valuables Pocket w/ Lockable Feature
- Insulated Beverage Pocket
- Lightweight Carbon Fiber Stand Legs
- Single Strap

COBRA TOUR STAFF BAG 24' \$650

STYLE	WEIGHT	MATERIAL	POCKETS
909699	11 lbs	Shell: 100% Polyurethane Lining: 100% Polyester	11

- Cobra® x Vessel Collaboration
- Tour Validated Staff Bag Offers Premium Storage and Performance
- 6-way Top with Full Length Club Dividers
- Dual Oversized Apparel Pockets
- Fleece Lined Valuables Pocket
- Insulated Beverage Pocket

COBRA CORE STAFF BAG \$650

STYLE	WEIGHT	MATERIAL	POCKETS
909629	11 lbs	Shell: 100% Polyurethane Lining: 100% Polyester	11

- Cobra® x Vessel Collaboration
- Tour Validated Staff Bag Offers Premium Storage and Performance
- 6-way Top with Full Length Club Dividers
- Dual Oversized Apparel Pockets
- Fleece Lined Valuables Pocket
- Insulated Beverage Pocket



03 Quiet Shade/Navy Blazer



08 Black/White



08 Black/White



02 Navy Blazer/Ski Patrol



03 Quiet Shade/Navy Blazer



04 Ski Patrol/Black



18 Black Camo



18 Black Camo



02 Navy Blazer/Ski Patrol



03 Quiet Shade/Navy Blazer



07 Elderberry/Black



08 Black/White

ULTRALIGHT PRO+ STAND BAG \$250

STYLE	WEIGHT	MATERIAL	POCKETS
909525	5 lbs	100% Polyester	8

- Designed for versatility, this bag provides all the storage you might need and is still light enough to carry for 18 holes with ease.
- Lightweight – Easy to carry at only 5lbs.
- Storage with a Purpose – 8 different pockets including a velour-lined range finder pocket and valuables pocket.
- Oversized Insulated Pocket – Fit up to eleven cans of your favorite beverage.
- New Stable Leg Design – An updated leg design provides a streamlined aesthetic and lower CG yields a more stable bag.
- New Easy Flex Base – Better ground contact for even more stability.

ULTRALIGHT PRO STAND BAG \$225

STYLE	WEIGHT	MATERIAL	POCKETS
909526	4 lbs	100% Polyester	7

- A true lightweight carry bag. Gives golfers exactly what they need, in a comfortable, sleek package
- Lightweight – Designed for golfers who like to walk. Super easy to carry at only 4lbs.
- Storage with a Purpose – 7 pockets thoughtfully designed to carry everything a golfer needs and that's it. No more, no less.
- Magnetic Range finder slip pocket.
- New Stable Leg Design – An updated leg design provides a streamlined aesthetic and lower CG yields a more stable bag.
- New Easy Flex Base – Better ground contact for even more stability.

ULTRALIGHT PRO CART BAG \$250

STYLE	WEIGHT	MATERIAL	POCKETS
909528	5 lbs	100% Polyester	11

- Maximum Storage and easy access to ensure all on-course essentials are on-hand to get the most out of every round
- Maximum Storage – 11 different pockets, including dual oversized apparel pockets.
- Magnetic Range Finder Pocket – Easy access to your rangefinder with the magnetic pocket.
- 14-Way Top including 3 full-length dividers for easy access to your clubs.
- Insulated Pocket – Keep up to nine cans of your favorite beverage cold.
- Pass-Thru – Built in pass-thru to attach to a cart without restricting pocket access.



ULTRALIGHT SUNDAY BAG \$129

STYLE	WEIGHT	MATERIAL	POCKETS
909311	3.8 lbs	100% Polyester	5

- 3-way top with individually lined club dividers and top grab handle
- Oversized apparel pocket
- Mesh beverage pocket
- Customizable ball pocket



ULTRALIGHT PRO CRESTING STAND BAG \$225

STYLE	WEIGHT	MATERIAL	POCKETS
909569	4 lbs	100% Polyester	7

- Lightweight – designed for golfers who like to walk. Super easy to carry at only 4 lbs.
- Storage with a purpose – 7 pockets thoughtfully designed to carry everything a golfer needs and that's it. No more, no less.
- New Stable Leg Design – An updated leg design provides a streamlined aesthetic and lower CG yields a more stable bag.
- New Easy Flex Base – Better ground contact for even more stability.



ULTRALIGHT PENCIL BAG \$140

STYLE	WEIGHT	MATERIAL	POCKETS
909527	3 lbs	100% Polyester	5

- 2-way top with single top divider
- Dual Pockets – designed to provide a simple storage solution for tees and balls
- Internal storage for your valuables
- Dual-Strap Option – Allows for a golfer to carry with single or double straps



ULTRADRY PRO STAND BAG \$259

STYLE	WEIGHT	MATERIAL	POCKETS
909479	4.5 lbs	100% Polyester	5

- Waterproof – Seam sealed zippered pockets to protect your belongings from the elements.
- Lightweight – Easy to carry at only 4.5lbs.
- New Swivel Strap – The new shoulder clip allows the bag to swivel as you move, making walking 18 holes easier than ever.
- New Stable Leg Design – An updated leg design provides a streamlined aesthetic and lower CG yields a more stable bag.
- New Easy Flex Base – Better ground contact for even more stability.
- Number of Pockets: 5
- 5-Way top



ULTRADRY PRO CART BAG \$279

STYLE	WEIGHT	MATERIAL	POCKETS
909480	5.3 lbs	100% Polyester	7

- Waterproof – Seam sealed zippered pockets to protect your belongings from the elements.
- 14-Way Top – Full length putter divider for easier access to the flatstick.
- Lightweight – Easy to carry at only 5lbs.
- Dual Apparel Pockets – Two oversized apparel pockets for increased storage.
- Pass-Thru – Built in pass-thru to attach to a cart without restricting pocket access.
- Number of Pockets: 7



COBRA TOUR TECH CAP

\$32

STYLE	SIZE	MATERIAL
909727	OSFA	Shell: 95% Polyester 5% Elastane Front Lining: 100% Polyester Lower Shell Outer Surface: 100% Polyester

- 6-Panel Cap with framed COBRA silicone linear patch.
- Perfect Fit – Years of research brings to life the most comfortable hat we've ever made.
- 110% Comfort – Flexfit 110 sweatband wicks moisture away and provides all the comfort you need on and off the course.
- Premium Materials – New technical performance material that's lightweight and moisture wicking.
- One Size Fits All – The classic snapback closure allows you to adjust your desired size.

COBRA CROWN C PATCH CAP

\$32

STYLE	SIZE	MATERIAL
909728	OSFA	Shell: 95% Polyester 5% Elastane Front Lining: 100% Polyester Lower Shell Outer Surface: 100% Polyester

- 6-Panel Cap with Crown C and COBRA silicone flag patch.
- Perfect Fit – Years of research brings to life the most comfortable hat we've ever made.
- 110% Comfort – Flexfit 110 sweatband wicks moisture away and provides all the comfort you need on and off the course.
- Premium Materials – New technical performance material that's lightweight and moisture wicking.
- One Size Fits All – The classic snapback closure allows you to adjust your desired size.



COBRA 1973 PATCH CAP

\$32

STYLE	SIZE	MATERIAL
909729	OSFA	Shell: 95% Polyester 5% Elastane Front Lining: 100% Polyester Lower Shell Outer Surface: 100% Polyester

- 6-Panel Cap with COBRA 'SINCE 1973' woven patch.
- Perfect Fit – Years of research brings to life the most comfortable hat we've ever made.
- 110% Comfort – Flexfit 110 sweatband wicks moisture away and provides all the comfort you need on and off the course.
- Premium Materials – New technical performance material that's lightweight and moisture wicking.
- One Size Fits All – The classic snapback closure allows you to adjust your desired size.

COBRA SCRIPT CAP

\$32

STYLE	SIZE	MATERIAL
909730	OSFA	Shell: 95% Polyester 5% Elastane Front Lining: 100% Polyester Lower Shell Outer Surface: 100% Polyester

- Classic 5-Panel Cap with 3D Embroidered COBRA script logo.
- Perfect Fit – Years of research brings to life the most comfortable hat we've ever made.
- 110% Comfort – Flexfit 110 sweatband wicks moisture away and provides all the comfort you need on and off the course.
- Premium Materials – New technical performance material that's lightweight and moisture wicking.
- One Size Fits All – The classic snapback closure allows you to adjust your desired size.



TOUR CROWN 110 CAP

\$30

STYLE	SIZE	MATERIAL
909491	OSFA	Shell: 95% Polyester 5% Elastane Front Lining: 100% Polyester Lower Shell Outer Surface: 100% Polyester

- Perfect Fit – Years of research brings to life the most comfortable hat we've ever made.
- 110% Comfort – Flexfit 110 sweatband wicks moisture away and provides all the comfort you need on and off the course.
- Technical Materials – New technical performance material that's lightweight and moisture wicking.
- One Size Fits All – The classic snapback closure allows you to adjust your desired size.
- 3D angular silicon branding execution



01 Puma Black/White Glow



02 White Glow/Vine



03 Ash Gray/Deep Navy

SMALL CROWN CAP

\$32

STYLE	SIZE	MATERIAL
909668	OSFA	Shell: 99% Polyester 1% Elastane Lining: 100% Polyester Lower Shell Outer Surface: 100% Polyester

- Perfect Fit – Years of research brings to life the most comfortable hat we've ever made.
- 110% Comfort – Flexfit 110 sweatband wicks moisture away and provides all the comfort you need on and off the course.
- Premium Materials – New technical performance material that's lightweight and moisture wicking.
- One Size Fits All – The classic snapback closure allows you to adjust your desired size.



01 Black



02 White



03 Navy

KING COBRA ROPE SNAPBACK CAP

\$32

STYLE	SIZE	MATERIAL
909591	OSFA	Shell: 95% Polyester 5% Elastane Front Lining: 100% Polyester Lower Shell Outer Surface: 95% Polyester 5% Elastane

- 110% Comfort – Flexfit 110 sweatband wicks moisture away and provides all the comfort you need on and off the course.
- Technical Materials – New technical performance material that's lightweight and moisture wicking.
- One Size Fits All – The classic snapback closure allows you to adjust your desired size.
- 3D embroidered retro KING Cobra Logo



01 Black

ULTRADRY CAP

\$30

STYLE	SIZE	MATERIAL
909496	S/M, L/XL	Shell: 97% Polyester 3% Elastane Front Lining: 100% Polyester

- Pre-curve stretch fit cap
- 110% Comfort – Flexfit 110 sweatband wicks moisture away and provides all the comfort you need on and off the course.
- Water resistant, seam sealed construction for all elements
- Reflective Crown C and embossed Cobra wordmark across backside
- Available in S/M and L/XL



CAMO CROWN C SNAPBACK CAP \$32

STYLE	SIZE	MATERIAL
909532	OSFA	Shell: 90% Polyester, 10% Elastane Front Lining: 100% Polyester Lower Shell Outer Surface: 100% Cotton

- Special-edition digi-camo color block.
- Perfect Fit – Years of research brings to life the most comfortable hat we've ever made.
- 110% Comfort – Flexfit 110 sweatband wicks moisture away and provides all the comfort you need on and off the course.
- Premium Materials – New technical performance material that's lightweight and moisture wicking.
- One Size Fits All – The classic snapback closure allows you to adjust your desired size.

STARS AND STRIPES CROWN C SNAPBACK CAP \$32

STYLE	SIZE	MATERIAL
909533	OSFA	Shell: 90% Polyester, 10% Elastane Front Lining: 100% Polyester Lower Shell Outer Surface: 100% Cotton

- Special-edition Stars and Stripes theme featuring a 3D embroidered Crown C with American flag details.
- Perfect Fit – Years of research brings to life the most comfortable hat we've ever made.
- 110% Comfort – Flexfit 110 sweatband wicks moisture away and provides all the comfort you need on and off the course.
- Premium Materials – New technical performance material that's lightweight and moisture wicking.
- One Size Fits All – The classic snapback closure allows you to adjust your desired size.



COBRA CROWN TRUCKER CAP \$30

STYLE	SIZE	MATERIAL
909593	OSFA	Front Panel: 96% Polyester 4% Elastane Side/Back Panel: 100% Polyester Front Lining: 100% Polyester Upper Shell Outer Surface: 96% Polyester 4% Elastane Lower Shell Outer Surface: 100% Polyester

- 110% Comfort – Flexfit 110 sweatband wicks moisture away and provides all the comfort you need on and off the course.
- One Size Fits All – The classic snapback closure allows you to adjust your desired size.

KING COBRA HIGH CROWN VISOR \$30

STYLE	SIZE	MATERIAL
909592	OSFA	Shell: 95% Polyester 5% Elastane Lining: 100% Polyester Lower Shell Outer Surface: 100% Polyester

- Pre-curved adjustable visor with velcro closure
- Technical Materials – New technical performance material that's lightweight and moisture wicking.
- 3D embroidered retro KING Cobra Logo



WOMEN'S CROWN ADJUSTABLE CAP \$24

WOMEN'S COBRA CROWN VISOR \$22

STYLE	SIZE	MATERIAL
909499	OSFA	Shell: 100% Polyester Front Lining: 80% Polyester 20% Cotton Back Lining: 100% Polyester

STYLE	SIZE	MATERIAL
909595	OSFA	Shell: 96% Polyester, 4% Elastane Front Lining: 100% Polyester Lower Shell Outer Surface: 100% Polyester

- Pre curve, adjustable cap
- Moisture wicking performance sweatband
- Side and back panel ventilation
- Hair friendly velcro
- Silicone Crown C logo

- Pre-curved adjustable visor with velcro closure
- Moisture wicking performance sweatband
- 3D angular silicon 'Crown C' branding



TOUR CROWN AUSSIE BUCKET \$44

YOUTH CROWN CAP \$22

STYLE	SIZE	MATERIAL
909647	OSFA	Shell: 95% Polyester 5% Elastane Front Lining: 100% Polyester Lower Shell Outer Surface: 95% Polyester 5% Elastane

STYLE	SIZE	MATERIAL
909494	OSFA	Shell: 95% Polyester 5% Elastane Front Lining: 100% Polyester Lower Shell Outer Surface: 95% Polyester 5% Elastane

- All around brim designed to keep the sun off your face and ears
- 3D angular front silicone Crown C branding
- Mesh vents for ultimate breathability
- Adjustable draw cord for the best personal fit

- Perfect Fit – Years of research brings to life the most comfortable hat we've ever made.
- 110% Comfort – Flexfit 110 sweatband wicks moisture away and provides all the comfort you need on and off the course.
- Technical Materials – New technical performance material that's lightweight and moisture wicking.
- One Size Fits All – The classic snapback closure allows you to adjust your desired size.
- 3D angular silicon branding execution



01
Bright White



01
Bright White



01
Bright White

PUR TOUR GLOVE

\$24

STYLE	SIZE	MATERIAL
LH: 909458 RH: 909459 CLH: 909460	S, M, ML, L, XL	Palm: 100% Leather Backhand: 100% Leather Gusset: 100% Leather Wrist Strap: 100% Polyurethane

- PURFIT Tech – Form-fitted construction and contoured wristband for ultimate comfort.
- Feel – Premium AAA Cabretta Leather (the highest grade).
- Moisture Control – Strategically placed micro-perforations provide breathability while the wrist sweatband wicks moisture away.
- Premium Details – Debossed snake logo and hidden woven labels provide an upgraded look.

PUR TECH GLOVE

\$20

STYLE	SIZE	MATERIAL
LH: 909461 RH: 909462 CLH: 909463	S, M, ML, L, XL	Palm: 100% Leather, Backhand: 90% Leather/10% Polyester Gusset: 100% Polyester Wrist Strap: 100% Polyurethane

- PURFIT Tech – 4-way stretch mesh and contoured wristband provides a comfortable fit.
- Feel – Premium Cabretta Leather for a soft feel.
- Breathability – Strategically placed micro-perforations and a knit insert yield extreme breathability and moisture control.
- Premium Details – Embossed logos and premium trims provide an upgraded look.

MICROGRIP FLEX GLOVE

\$13

STYLE	SIZE	MATERIAL
LH: 909464 RH: 909465 CLH: 909466	S, M, ML, L, XL	Palm: 80% Polyurethane/20% Leather Backhand: 90% Polyurethane/10% Polyester Gusset: 100% Polyester Wrist Strap: 100% Silicone

- Durability – Sheep leather palm and thumb inserts provide exceptional feel while also allowing for a longer lasting golf glove.
- Breathability – Strategically placed micro-perforations and lycra-mesh insert yield extreme breathability and moisture control.
- Fit – Lightweight mesh and form-fitted wristband provide exceptional comfort.



01
Black



01
Black



01
Black

STORMGRIP RAIN GLOVE PAIR

\$24

STYLE	SIZE	MATERIAL
909467	S, M, ML, L, XL	Palm: 100% Polyester Backhand: 50% Nylon, 50% Polyester Wrist Strap: 100% Silicone

- Superior Grip: StormGrip Suede provides maximum grip in wet conditions.
- Dry Performance: Our proprietary moisture membrane keeps your hands dry even in the harshest conditions.
- Lightweight mesh and form-fitted wristband provide exceptional comfort.

STORMGRIP WINTER GLOVE PAIR

\$24

STYLE	SIZE	MATERIAL
909469	S, M, ML, L, XL	Palm: 100% Polyester Backhand: 100% Polyester

- PURFIT Tech – 4-way stretch mesh and contoured wristband provides a comfortable fit.
- Feel – Premium Cabretta Leather for a soft feel.
- Breathability – Strategically placed micro-perforations and a knit insert yield extreme breathability and moisture control.
- Premium Details – Embossed logos and premium trims provide an upgraded look.

WINTER MITTS

\$28

STYLE	SIZE	MATERIAL
909568	OSFA	Shell: 100% polyamide Lining: 100% polyester

- Foldable – A hidden pouch on the left glove allows you to fold the gloves and pack for safe keeping.
- Insulation – Warm fleece lines the back of the glove to provide ultimate comfort and warmth.
- OSFA - One Size Fits All



01
Bright White



01
Bright White

WOMEN'S PUR TOUR GLOVE LH \$24

STYLE	SIZE	MATERIAL
909500	S, M, ML, L, XL	Palm: 100% Leather Backhand: 100% Leather Gusset: 100% Leather Wrist Strap: 100% Polyurethane

- PURFIT Tech – Form-fitted construction and contoured wristband for ultimate comfort.
- Feel – Premium AAA Cabretta Leather (the highest grade).
- Moisture Control – Strategically placed micro-perforations provide breathability while the wrist sweatband wicks moisture away.
- Premium Details – Debossed snake logo and hidden woven labels provide an upgraded look.

WOMEN'S PUR TECH GLOVE LH \$20

STYLE	SIZE	MATERIAL
909470	S, M, L	Palm: 100% Leather Backhand: 80% Leather/20% Polyester Gusset: 100% Polyester Wrist Strap: 100% Polyurethane

- PURFIT Tech – 4-way stretch mesh and contoured wristband provides a comfortable fit.
- Feel – Premium Cabretta Leather for a soft feel.
- Breathability – Strategically placed micro-perforations and a knit insert yield extreme breathability and moisture control.
- Premium Details – Embossed logos and premium trims provide an upgraded look.



01
Bright White



01
White

WOMEN'S MICROGRIP FLEX GLOVE LH \$13

STYLE	SIZE	MATERIAL
909472	S, M, L	Palm: 80% Polyurethane/20% Leather Backhand: 90% Polyurethane/10% Polyester Gusset: 100% Polyester Wrist Strap: 100% Silicone

- Durability – Sheep leather palm and thumb inserts provide exceptional feel while also allowing for a longer lasting golf glove.
- Breathability – Strategically placed micro-perforations and lycra-mesh insert yield extreme breathability and moisture control.
- Fit – Lightweight mesh and form-fitted wristband provide exceptional comfort.

YOUTH MICROGRIP FLEX GLOVE LH \$13

STYLE	SIZE	MATERIAL
909474	S, M, L	Palm: 100% Polyurethane Backhand: 90% Polyurethane/10% Polyester Gusset: 100% Polyester Wrist Strap : 100% Silicone

- Durability – Sheep leather palm and thumb inserts provide exceptional feel while also allowing for a longer lasting golf glove.
- Breathability – Strategically placed micro-perforations and lycra-mesh insert yield extreme breathability and moisture control.
- Fit – Lightweight mesh and form-fitted wristband provide exceptional comfort.



01
Black



01
Black

CROWN ROLLING CLUB BAG \$220

STYLE	SIZE	MATERIAL
909398	17" x 10.5" x 52"	Shell: 100% Polyester Lining: 100% Polyester

- Large main compartment with two-way zip up
- External pockets for extra storage
- Multiple top and front grab/carry handles
- ID Card holder
- Top and side carry handle
- Durable heather material with Crown C branding
- Oversize wheels for easy transition when traveling

CROWN C BACKPACK \$130

STYLE	SIZE	MATERIAL
909653	17" x 10.5" x 52"	Shell: 93% Polyester, 7% Nylon Lining: 100% Polyester Back: 100% Polyester Shoulder strap: 100% Polyester Decoration: 100% Synthetic leather

- Durable black outer material with debossed Crown C branding
- Padded side access lab top pocket with internal velcro strap for extra security
- Internal iPad sleeve
- Spandex nylon stretch side water bottle pocket
- Plush microfiber top valuables pocket
- Slip through slot for easy stacking on rolling carry on
- Top grab handle and comfort shoulder straps
- Secondary pocket with organized storage



01
Black

CROWN C CARRY ON \$250

STYLE	SIZE	MATERIAL
909650	13" x 21.5" x 9.5"	Shell: 57% Nylon, 43% Polyester Lining: 100% Polyester Decoration: 100% Synthetic leather

- Carry on rolling luggage
- Large main compartment with two-way zip and internal organization
- Bag extender zips up flat or can be extended to 65 mm
- Top and side handle carry
- Collapsible telescope handle with 3 different settings based on your preferred height
- Internal mesh pockets for organization and internal straps providing a secure fit
- Durable black outer material with debossed Crown C branding
- Roller wheels designed for smoother movements and versatility



COBRA MICROFIBER TOUR GOLF TOWEL \$32

STYLE	SIZE	MATERIAL
909599	OSFA	80% Polyester, 20% Polyamide

- Super absorbant microfiber based tour performance towel
- Double sided Cobra branding with center slit for hanging
- Care instructions: Machine wash cold. Do not iron. Hang dry only. Do not bleach.



COBRA TRI-FOLD TOWEL \$20

STYLE	SIZE	MATERIAL
909600	OSFA	80% Polyester, 20% Polyamide

- Super Absorbent
- Carabiner
- Care Instructions: Machine wash cold. Do not iron. Hang dry only. Do not bleach.



COBRA CRAZY SNAKE TOWEL \$36

STYLE	SIZE	MATERIAL
909696	OSFA	80% Polyester, 20% Polyamide

- Super absorbant microfiber based tour performance towel
- Center slit for hanging
- Care instructions: Machine wash cold. Do not iron. Hang dry only. Do not bleach.



COBRA SNAKE CAMO TOWEL \$36

STYLE	SIZE	MATERIAL
909697	OSFA	80% Polyester, 20% Polyamide

- Super absorbant microfiber based tour performance towel
- Center slit for hanging
- Care instructions: Machine wash cold. Do not iron. Hang dry only. Do not bleach.



COBRA SNAKESKIN TOWEL \$36

STYLE	SIZE	MATERIAL
909698	OSFA	80% Polyester, 20% Polyamide

- Super absorbant microfiber based tour performance towel
- Center slit for hanging
- Care instructions: Machine wash cold. Do not iron. Hang dry only. Do not bleach.



COBRA BRANDED UMBRELLA \$75

STYLE	SIZE	MATERIAL
909598	OSFA	80% Polyester, 20% Polyamide

- Reinforced fiberglass on primary, secondary, and tertiary ribs for durability
- Anti-slip silicone tip
- Cobra Golf branding



HIGH



1818 ASTON AVENUE CARLSBAD, CA 92008 | 800.917.3300 | WWW.COBRAGOLF.COM | @COBRAGOLF

REV 1 | UPDATED AUGUST 2023